

CONOTEC® Digital Temperature Controller

CONOTEC CO., LTD.

www.conotec.co.kr



FOX-2001D, 2001T, 2001F

Operating Manual

Model	Sensor	Output	Temp. Range	Function
FOX-2001D	NTC	relay (2EA)	-55.0°C ~ +99.9°C	temp. control
FOX-2001T	NTC	relay (3EA)	-55.0°C ~ +99.9°C	temp. control
FOX-2001F	NTC	relay (4EA)	-55.0°C ~ +99.9°C	temp. control

※ Thank you for selecting our products. Please read carefully this instruction to reduce any damages or operation mistakes.

Part name

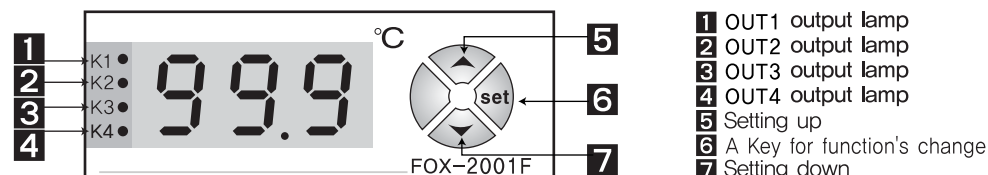

The function of each key.

- : A key to change of the programs & setting temperature.
- : A key to change of the temperature or the program's set values

Detailed manual

- St1** : setting for the 1-stage temperature (application model : 2001D, 2001T, 2001F)
- St2** : setting for the 2-stage temperature (application model : 2001D, 2001T, 2001F)
- St3** : setting for the 3-stage temperature (application model : 2001T, 2001F)
- St4** : setting for the 4-stage temperature (application model : 2001F)
- HSP** : Setting function of the highest limit of temperature range(Maximum set point allowed to the end user)
Impossible to set up the set value more than HSP set value
ex) HSP = 25.0°C setting ⇒ impossible to raise the set value more than 25.0°C
- LSP** : Setting function of the lowest limit of temperature range(Minimum set point allowed to the end user)
Impossible to set up the set value less than LSP set value
ex) LSP = 10.0°C setting ⇒ impossible to lower the set value less than 10.0°C
- Cor** : Correction of the present temperature.
- It is used for the correction of an discrepancy between the display temperature and real temperature.
ex) real temp. : 10.0°C → Cor : 0.0 ⇒ -2.0correction → 10.0°Cdisplay
display : 12.0°C
- LoC** : The lock function
- As a safety device, it is used in order not to change the set values except for the main user.
ON- setting for the lock function.
OFF- removal for the lock function
- EP1** : Selection of the Temp.1 or Cooling or Heating (application model : 2001D, 2001T, 2001F)
- dt1** : Delay time of the temperature 1 output (application model : 2001D, 2001T, 2001F)
It is widely used as the followings
- in case of operating the ON/OFF control very often,
(Cooler, Compressor and so on)
- to protect the operation machinery when re-input of the power supply or momentary stoppage of power supply
ex) if the set value is 13.0,
from a until b time → the relay is ON in the b point after as delay as the dt1 setting time (1min.30sec.).
(flickering the output lamp during the dt1 time)

- df1** : Setting for temperature deviation (application model : 2001D, 2001T, 2001F)
In the ON/OFF control, it needs at regular interval between ON and OFF.
- By operating the ON/OFF control frequently, the relay or its output contact can be damaged quickly and it also occurs the hunting(oscillating, chattering) by virtue of external noise. You can make use of the temperature deviation in order to protect its relay or contact and so on.

「 The method of the temp. deviation when ON/OFF control 」

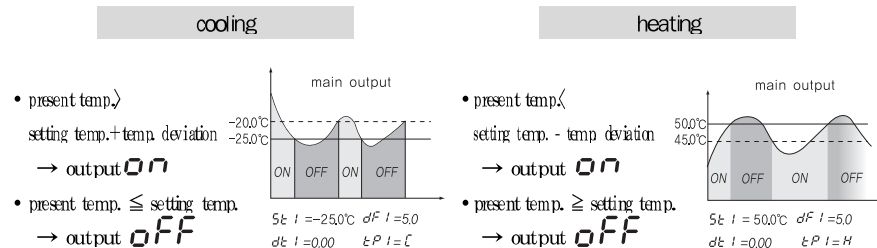

- EP2** : Selection of the Temp.2 or Cooling or Heating (application model : 2001D, 2001T, 2001F)
- dt2** : Delay time of the temperature 2 output
- Please refer to the above-mentioned no.9 (application model : 2001D, 2001T, 2001F)
- df2** : Temp. deviation of the temperature 2
- Please refer to the above-mentioned no.10 (application model : 2001D, 2001T, 2001F)
- EP3** : Selection of the Temp.3 or Cooling or Heating (application model : 2001T, 2001F)
- dt3** : Delay time of the temperature 3 output
- Please refer to the above-mentioned no.9 (application model : 2001T, 2001F)
- df3** : Temp. deviation of the temperature 3
- Please refer to the above-mentioned no.10 (application model : 2001T, 2001F)
- EP4** : Selection of the Temp.4 or Cooling or Heating (application model : 2001F)
- dt4** : Delay time of the temperature 4 output
- Please refer to the above-mentioned no.9 (application model : 2001F)
- df4** : Temp. deviation of the temperature 4
- Please refer to the above-mentioned no.10 (application model : 2001F)

Setting temperature

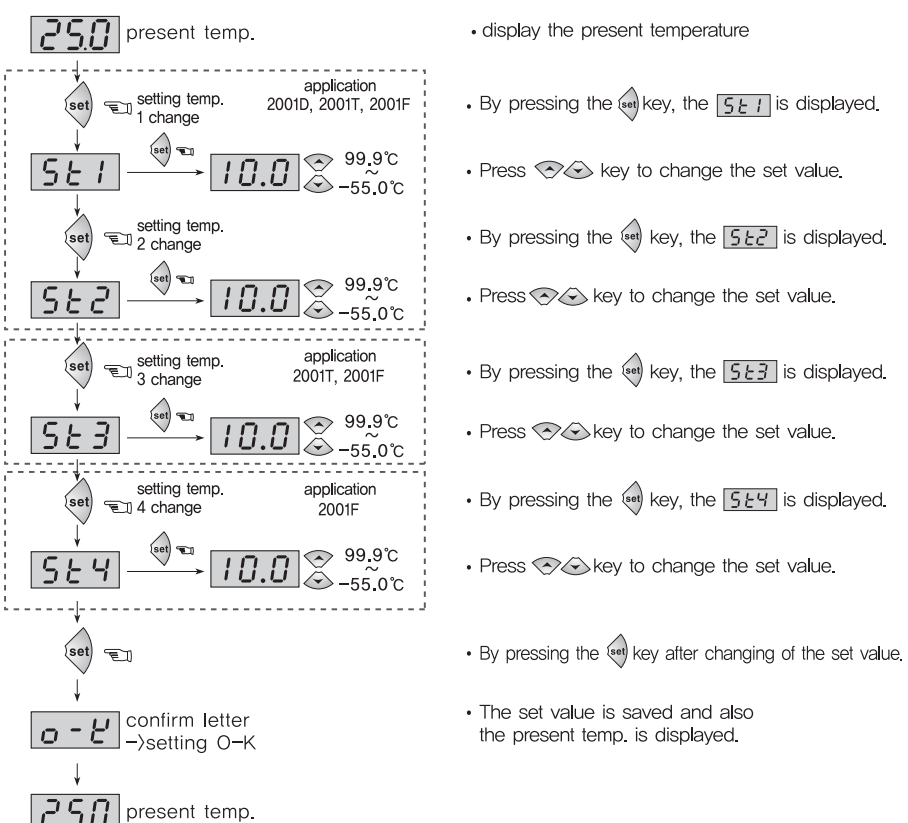

Setting for programs

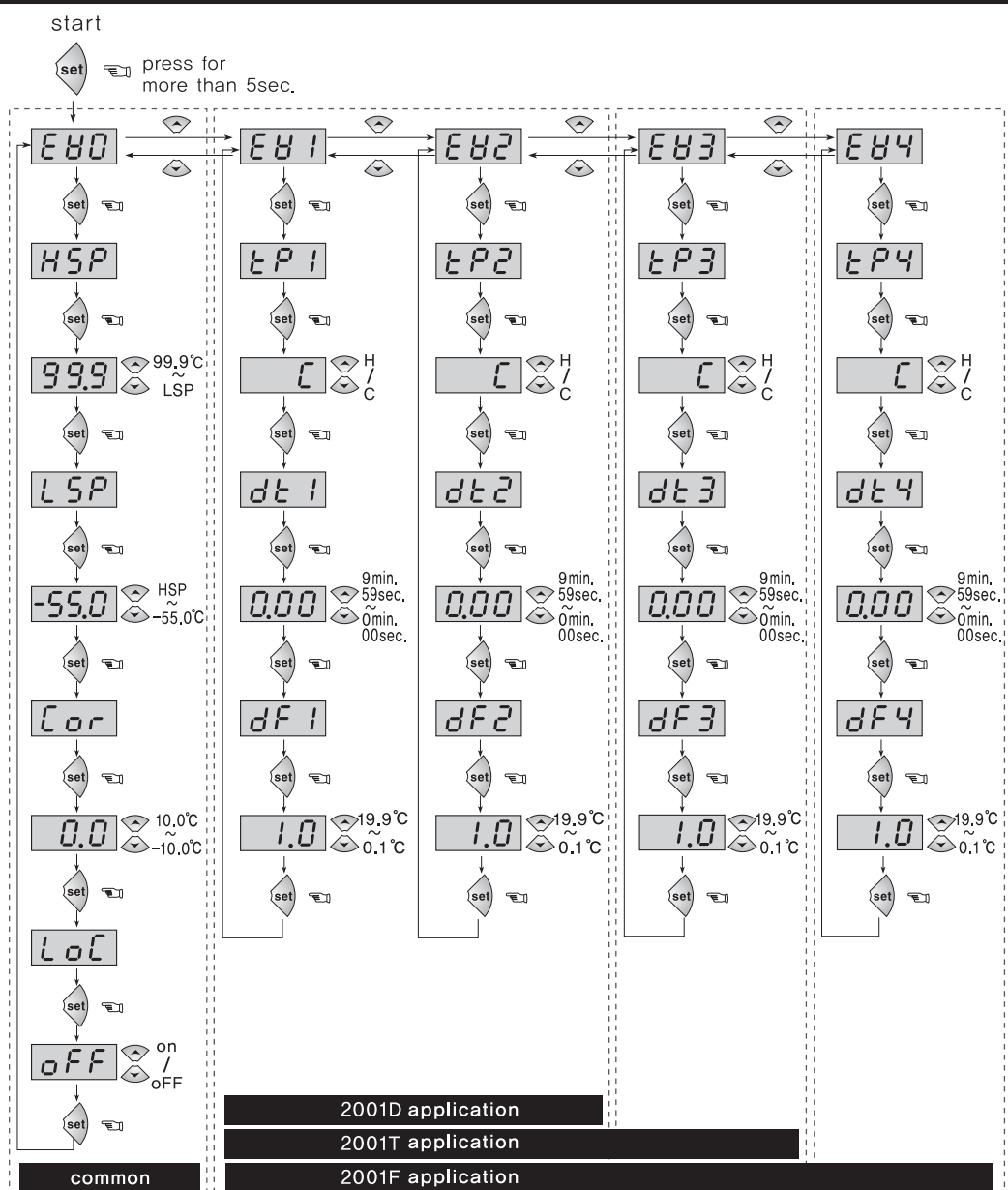

※To change it with program mode, press the set key for more than 5second in the present temperature display mode.
※The set or program mode is terminated if you press the set key for 2second, parameters set values are saved after the display shows OK letter or return to present temperature automatically after 30 second.

■ Temp. range & set value when deliver

	Function	Display	Range	Set values when deliver	Remarks
Setting temp.	Setting temp.1	St1	-55.0°C~+99.9°C	10.0°C	
	Setting temp.2	St2	-55.0°C~+99.9°C	10.0°C	
	Setting temp.3	St3	-55.0°C~+99.9°C	10.0°C	
	Setting temp.4	St4	-55.0°C~+99.9°C	10.0°C	
Program Setting	Setting for the highest limit of user	HSP	LSP~99.9°C	99.9°C	It is irrelevant to the relay output.
	Setting for the lowest limit of user	LSP	-55.0°C~HSP	-55.0°C	It is irrelevant to the relay output.
	Correction of temp.	Cor	-5.0°C~+5.0°C	0.0	correct for an discrepancy between the display temp. and real temp.
	Lock function	LoC	on/off	off	on setting for the lock function off removal of the lock function however, except for the setting temperature value
	Selection of the function for the temp. 1	tP1	C/H	C	C: for cooling H: for heating
	Delay time of the output for temp. 1	dt1	0.00~9.59minute	0minute	
	Temp. deviation for temp. 1	dF1	0.1°C~+19.9°C	1.0°C	hysteresis +
	Selection of the function for the temp.2	tP2	C/H	C	C: for cooling H: for heating
	Delay time of the output for temp. 2	dt2	0.00~9.59minute	0minute	
	Temp. deviation for temp. 2	dF2	0.1°C~+19.9°C	1.0°C	hysteresis +
	Selection of the function for the temp. 3	tP3	C/H	C	C: for cooling H: for heating
	Delay time of the output for temp. 3	dt3	0.00~9.59minute	0minute	
	Temp. deviation for temp. 3	dF3	0.1°C~+19.9°C	1.0°C	hysteresis +
	Selection of the function for the temp.4	tP4	C/H	C	C: for cooling H: for heating
Delay time of the output for temp. 4	dt4	0.00~9.59minute	0minute		
Temp. deviation for temp. 4	dF4	0.1°C~+19.9°C	1.0°C	hysteresis +	

■ Relay junction

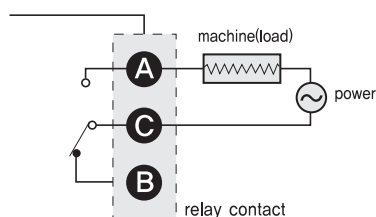

■ Connection

- FOX-2001D, 2001T

FOX-2001D/T

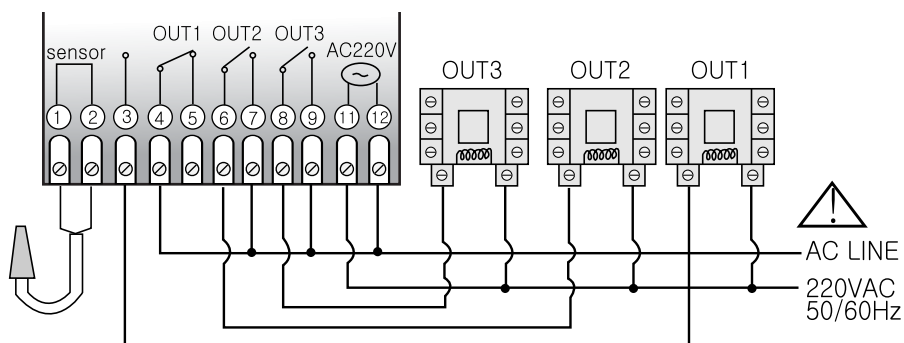

- FOX-2001F

FOX-2001F

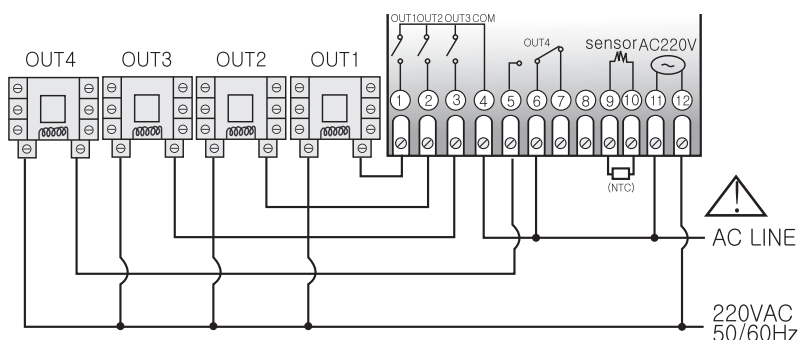

*output : 250VAC 2A
Please make use of the power relay or magnet surely.

■ Dimension

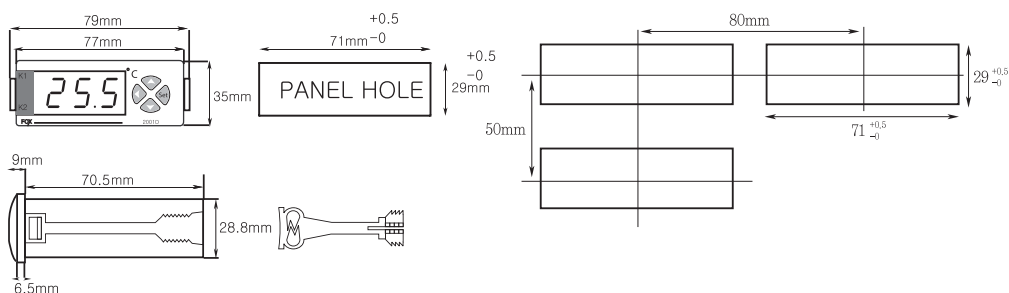

■ Caution for your safety

⚠ Safety

Pls use this item after installing the duplex safety device in which is applied at dangerous factors such as serious human injury or serious damages of property & important machine because this item is not designed as safety device

⚠ Safety Instruction and Hazard Warnings

- Please read the operating manual through completely before putting the device into operation.
- We will not assume any responsibility for damage to assets or persons caused by improper handling or failure to observe the safety instructions or hazard warnings.
- For safety and licensing reasons, unauthorized conversion and/or modification of the device is not permitted.
- Do not exceed the maximum permissible current - in case of higher loads, use a contactor of adequate power. Make sure that the supplied voltage matches the values specified for the instrument.
- The device must be adequately protected from water and dust as per the application and must be accessible via the use of appropriate tools
- The device must not be exposed to extreme temperature, sunlight, strong vibrations or high levels of humidity.
- Operation or installation is not permitted under unfavorable ambient conditions such as wetness or excessive induction loads or solenoid and dust, combustible gases, vapors or solvents, especially high-frequency noise
- Avoid operation or installation close to high-frequency fields such as welding devices, sewing machines, wireless transmitter, radio systems, SCR controller, etc
- Do not install the sensor cable nearby signal cable, power cable, load cable
- Please use the shield cable when the sensor cable's lengthen, however do not make it too much longer
- Please use the sensor cable without any cutting or flaw, blemish.
- The device is not a toy and should be kept away from children
- Installation work must only be carried out by suitably qualified personnel who are familiar with the hazards involved and with the relevant regulations.
- You shouldn't tinker with anything or the product may not be opened or disassembled unless you know what you're doing. Please ask us about this questioning

⚠ Danger

Attention ! Never work on electrical connections when the machine is switched on

Error message

- E r 1 Memory error. Turn the power off and turn it on again
If the error message persists, please request us A/S by return
- o -E Sensor error. The sensor is interrupted. Check the cable.
- S -E Sensor error. The sensor is short-circuited. Check the cable

■ The terms of guarantee : within 18months after shipment date.

■ Model & output spec.

	2001 (sensor : 1EA)	2001D (sensor : 1EA)	2001T (sensor : 1EA)	2001F (sensor : 1EA)	2000TT (sensor : 1EA)
temp. output	one-stage output	two-stage output	three-stage output	four-stage output	control by the temperature & time (for greenhouses)

	2001 (sensor : 1EA)	2002 (sensor : 1EA)	2003, 2003S (sensor : 1EA)	2004 (sensor : 2EA)	2005 (sensor : 2EA)	2006 (sensor : 2EA)
temp. output	○	○	○	○	○	temp.1 ○ temp.2 ○
alarm output	-	○	-	-	○	alarm1 ○ alarm2 ○
defrost output	-	-	○	○	○	-
FAN output	-	-	○	○	○	-

■ ex) application

- ex) Heater -> turn off at 30.0°C, turn on at 25.0°C => How to operate(setting for the temperature & programs)?

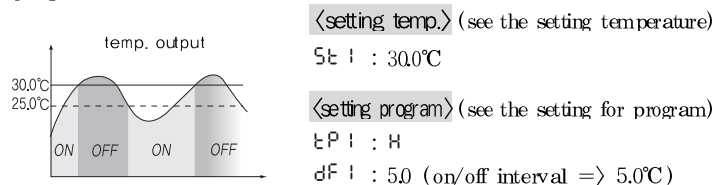

- Cooler -> turn off at 0.0°C, turn on at 2.0°C => How to operate(setting for the temperature & programs)?

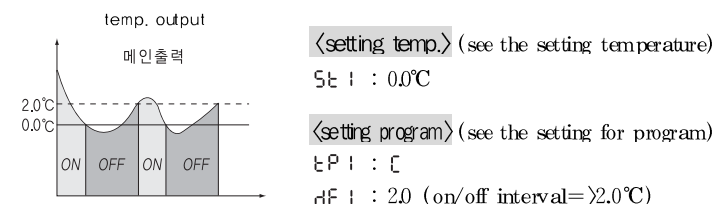

*The product's specification can be changed without any notification to improve its quality.

■ H. Office : B-112, Techno plaza 681-11
Junpo 1 dong, Busanjin-ku,
Busan, Korea
Factor y : B-408, 409, 410
Techno plaza 681-11
Junpo 1 dong, Busanjin-ku,
Busan, Korea
A/S TEL : +82-51-819-0426
FAX : +82-51-819-4562
E-mail : conotec@conotec.co.kr
Homepage : http://www.conotec.co.kr

*This device works proper operation with:
Surrounding Temp. : 0°C~60°C
Surrounding Humi. : below 80%RH
Regular power : 220VAC±10% 50/60Hz