

Operating Manual



FOX-1CH



FOX-1PH

Thank you for purchasing the product of CONOTEC.

1 Safety

※ Pls use this item after installing the duplex safety device in which is applied at dangerous factors such as serious human injury or serious damages of property & important machine because this item is not designed as safety device

WARNING

- As the product is not manufactured as safety equipment, make sure to use this product after mounting double safety device when using it for the purpose of controlling a device having risk of personal injury, equipment damage or huge property loss.
- Do not cut the wire or make check-up or maintenance when the power supply is connected.
- Make sure to check the socket number before connecting the power.
- Never disassemble process, improve or repair this equipment.

CAUTION

- Please carefully read and digest the operation procedure and safety related regulations or WARNING descriptions prior to the use of product, and make sure to operate the product only per the relevant specification or within the corresponding capacity rating.
- Do not make wiring or install the product on motor or solenoid with large inductive loads. When extending the sensor, use the shielded wire not extending the extension wire length unnecessarily long.
- Do not use the components generating arc when opening and closing under same power supply line or near to power supply.
- Keep the power supply line away from high voltage wire, and avoid installation at the locations subject to severe moisture, oily content and dust.
- Do not install the product at places exposed to direct sun light or rain.
- Do not install the product at places subject to strong magnetism or severe noise, vibration and impact.
- Keep the product far away from the places directly producing strong alkali or acidic substances using separate conduit for wiring.
- Do not spray water on the product for cleaning purpose when installed at kitchen area.
- Do not install at those places under the temperature and/or moisture exceeding the rated capacity.
- Use the product paying attention not to have disconnected sensor wiring or defect.
- Allow the sensor wiring stay away from signal, power supply, drive and load wires using separate conduit for wiring.
- Please note that no warranty services shall be provided when the product is disassembled or modified at user's own discretion.
- The mark shown on Terminal Wiring Diagram is a safety notice notifying warning or caution.
- Do not use the product at places near to the devices generating strong high frequency noise (High frequency welding machine, high frequency sawing machine, high frequency radio, large capacity SCR controller).
- Using the product with procedures not specified by the manufacture may incur the personal injury or property damage.
- Not being a toy, do not allow children touch the product.
- Make sure to execute the installation only by the skilled person with related industry or authorized personnel.
- Daesung ENG shall assume absolutely no responsibility of whatsoever nature for those damages and/or losses incurred due to the operation not complying with above WARNING or NOTE descriptions or negligence and/or fault of user.

Danger

- Caution, Danger of electric shock
- Electric shock - Do not touch AC board during on power because of electric shock.
- Please intercept input power surely when input power check.

2 Composition

Model	Sensor	Temp.range	Size(mm)	Output	Function
1PH	PT100Ω	-50℃~400℃	77(W)x35(H)	100~240VAC 50/60Hz	Temp.
1CH	K(CA)	-50℃~400℃	77(W)x35(H)	100~240VAC 50/60Hz	Temp.
1PH-D	PT100Ω	-50℃~400℃	77(W)x35(H)	DC12 ~ 40V	Temp.
1CH-D	K(CA)	-50℃~400℃	77(W)x35(H)	DC12 ~ 40V	Temp.

3 Part name



- Setting up
- Setting down
- Output
- Change function switch

User mode change & installer mode function setting

- User Mode change (Setting up Temperature)
 - Pressing this key once, flashes the letter SET, pressing once again, flashes the set value.
 - Change the set value with these keys.
 - Stores the set value with this key by pressing once again.

- Installer Mode Function setting
 - If press **Set** key for more than 5 seconds, displays and set in order such as user setting upper limit, lower limit temperature, C/H select, delay time, deviation temperature, temperature correction, etc..
 - Each model setting is set to change with keys and press **Set** when change to the next mode.

After input all the setting value, and **0-K** message, then return to the current temperature.



☎ :051-37133855-6

☎ :09014284236

WWW.ARCOKALIA.COM

4 Connection

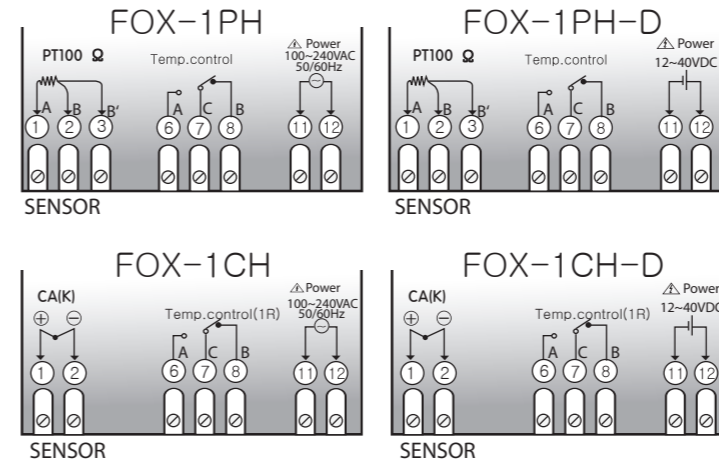

Relay junction

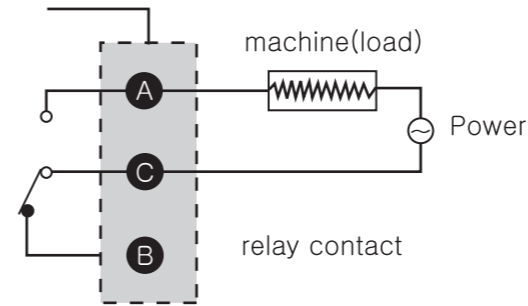

※ Relay contact capacity - less than 250VAC 2A
 In case of using the load exceeding the capacity of the contact, it caused fused contact, connection error.

5 Dimension

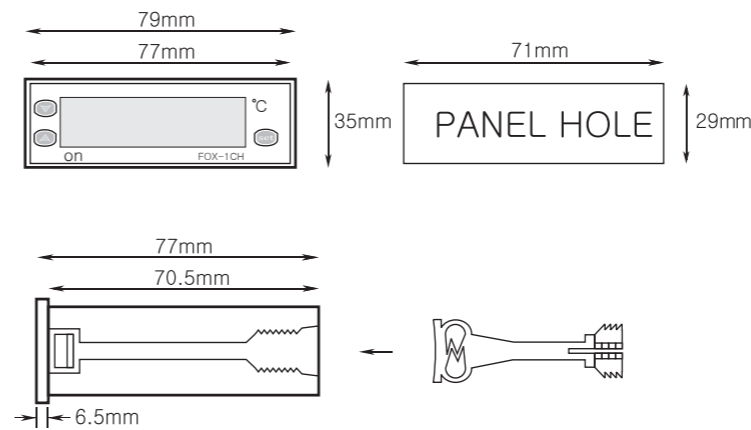

6 Sequence

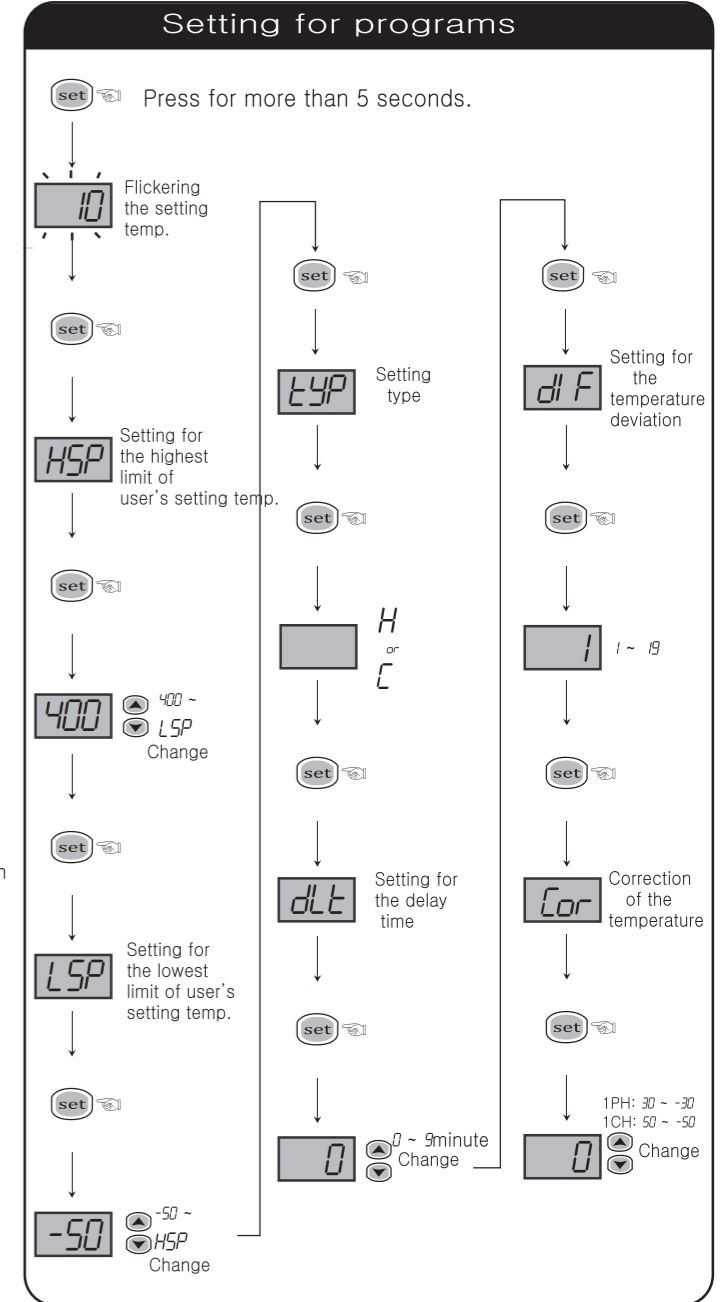
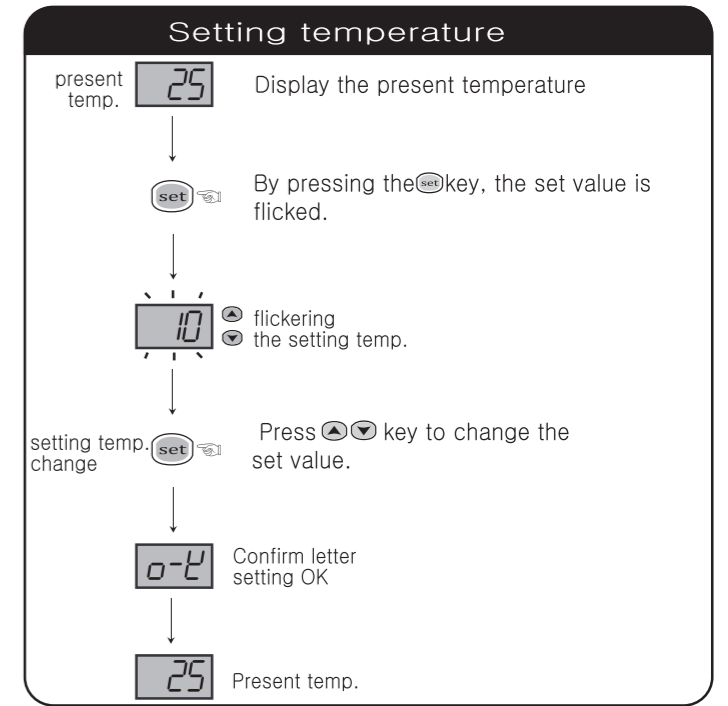

7 Detailed manual

HSP : Setting function of the highest limit of temperature range (Maximum set point allowed to the end user)
 -Impossible to set up the set value more than **HSP** set value
 ex) **HSP** = 25°C setting → impossible to raise the set value more than 25°C

LSP : Setting function of the lowest limit of temperature range (Minimum set point allowed to the end user)
 -Impossible to set up the set value less than **LSP** set value
 ex) **LSP** = 10°C setting → impossible to lower the set value less than 10°C

LYP : Selection of the Cooling(**CoL**) & Heating(**HEt**)

dLT : Delay time of the output

-in case of operation machinery when re-input of the power supply or momentary stoppage of power supply

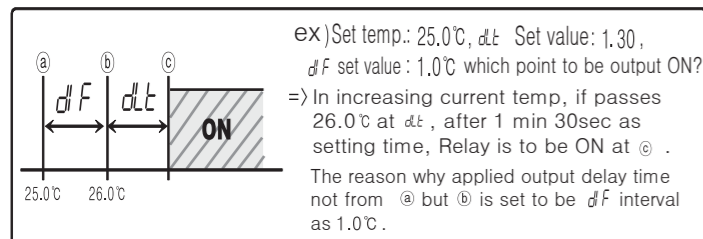

DIF : Setting for temperature deviation

- In the ON/OFF control, it need at regular interval between ON and OFF
 - By operating the ON/OFF control frequently, the relay or its output contact can be damaged quickly and it also occurs the hunting(oscillating, chattering) by virtue of external noise, You can make use of the temperature deviation in order to protect its relay or contact and so on

cooling

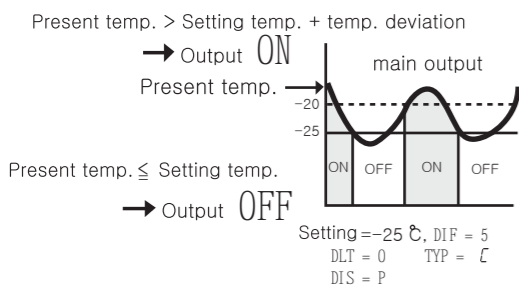

heating

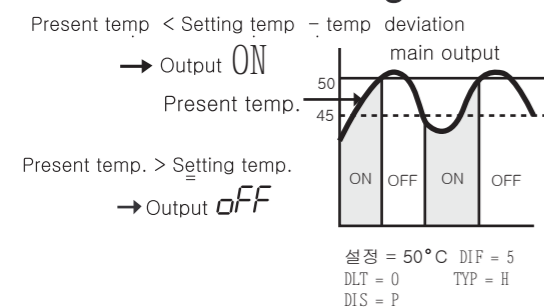

Cor : Correction of the present temperature.
 It is used for the correction of an discrepancy between the display temperature and an actual temperature.

ex) actual temp : 10°C → **Cor** : 0.0 → -2 correction → 10°C display
 display : 12°C change

8 Temp.range&set value when deliver

Function	Display	Model	FOX-1PH	Set value when deliver	FOX-1CH
Highest limit of temp. range	HSP		+400°C	+400°C	+400°C
Lowest limit of temp. range	LSP		-50°C	-50°C	-50°C
C/H	LYP		C / H	H	C / H
Delay time	dLT		0 ~ 9 Min	0Min	0 ~ 9Min
Temp. deviation	dIF		1 ~ 19°C	1°C	1 ~ 19°C
Correction of temp.	Cor		± 30°C	0°C	±50

※ It shall be turned off at the setting temperature because the temperature deviation is only one sided deviation, + or - ON is depended on the deviation setting.

■ ex) application

ex) Heater → turn off at 30°C, turn on at 25°C

How to operate(setting for the temperature&programs)?

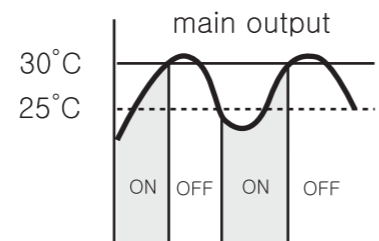

<Setting temp.> (see the setting temperature)

setting : 30°C

<Setting program> (see the setting for program)

LYP : **HEt**

dIF : P(deviation → one side, set point → off)

dIF : 5 (on/off interval → 5)

ex) Cooler → turn off at 0°C, turn on at 2°C

How to operate(setting for the temperature&programs)?

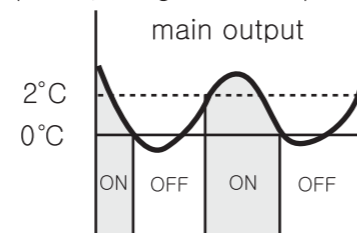

<Setting temp.> (see the setting temperature)

setting : 0°C

<Setting program> (see the setting for program)

typ : **CoL**

dis : p(deviation → one side, set point → off)

dif : 2 (on/off interval → 2)

9 Error message

• Indicating ERROR on using items

- This **E_r** is the damage of memory data for various of inner -DATA due to be got nosied strongly from outside while using this items. Please request us A/S by return.
- Although our controller is designed as the complementary measures regarding these noise from outside, it is not endurable against these noise with endlessly. If noise(2KV) disordering become an inflow, the inner-part will be damaged.
- O-E(open error), S-E(short error) In this case, sensor error, the sensor is interrupted. Check the sensor cable. If the error message persists, please request A/S by return.

※ The product's specification can be changed without any notification to improve its quality

■ H.Office : CONOTEC B/D 2nd floor, 26, Yunsan-ro, Geumjeong-gu, Busan, 609-821 Rep. of KOREA
 Lab : CONOTEC B/D 3rd floor, 26, Yunsan-ro, Geumjeong-gu, Busan, 609-821 Rep. of KOREA
 Factory : CONOTEC B/D B1, 26, Yunsan-ro, Geumjeong-gu, Busan, 609-821 Rep. of KOREA
 A/S TEL : +82-51-819-0426
 E-mail : conotec@conotec.co.kr
 Homepage : www.conotec.co.kr

■ Main Products & Development
 - Digital Temperature /Humidity Controller
 - Digital Timer, Current/Voltage Meter
 - Other Products Development

MEMO



☎ :051-37133855-6

☎ :09014284236

WWW.ARCOKALIA.COM