



**new**

# Micro Drive **M100**

The Best Way to Save Money and Time

- Built-in C2 EMC Filter
- User-Friendly Design
  - DIN rail mountable
  - Side-by-side installation
  - Easy connection with RJ45 port
    - Modbus / Smart copier / Remote keypad / DriveView 7
- New UL 61800-5-1 Design
  - Enhanced isolation circuit
- Built-in DB Unit :  $\geq 1.5kW$
- Modbus in Advanced I/O Type



Built-in EMC Filter (C2 class)



Side-by-side Installation  
(2mm between drives)



DIN rail Mountable



Smart Copier  
(Parameter copy without power)



( 1 Phase 200~240V 0.1~2.2kW )

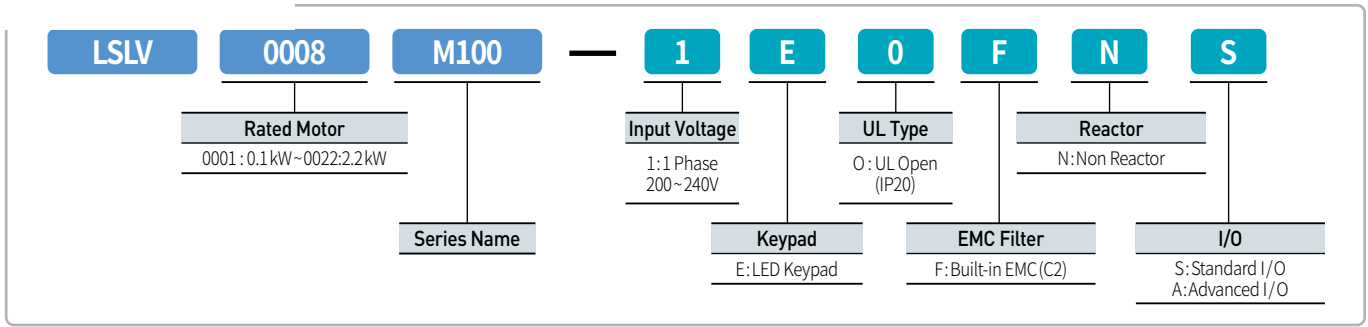

## Specification

LSLV M100-E0FN		0001	0002	0004	0008	0015	0022	
Applied Motor	Heavy Duty	HP	0.125	0.25	0.5	1.0	2.0	3.0
		kW	0.1	0.2	0.4	0.75	1.5	2.2
Rated Output	Rated Capacity (KVA)		0.3	0.6	0.95	1.9	3.0	4.5
	Rated Current (A)		0.8	1.4	2.4	4.2	7.5	10.0
	Frequency (Hz)		0~400Hz					
	Voltage (V)		3 phase 200-240V					
Rated Input	Rated Current (A)		1.0	1.8	3.7	7.1	13.6	18.7
	Frequency (Hz)		50~60Hz (±5%)					
	Voltage (V)		1 phase 200-240Vac (-15% to +10%)					
Cooling Type		Natural cooling			Forced fan cooling			
Weight (Kg)		0.66			1		1.45	

## Environment

Ambient Temperature*1)	-10~50°C (14~122°F), Ambient temperature under the condition of no ice or frost
Ambient Humidity	Relative humidity less than 95% RH (to avoid condensation forming)
Storage Temperature	-20~65°C (-4~149°F)
Surrounding Environment	Environment Level: 3C3(IEC60721-3-3) classifications (for SO <sub>2</sub> , H <sub>2</sub> S, CL, NO <sub>2</sub> ) No corrosive gas, flammable gas, oil mist and dust etc., indoors
Altitude / Oscillation	Below 1,000m, below 9.8m/sec <sup>2</sup> (1G)
Pressure	70~106 kPa

\*1) 0.1~0.2kW products can be operated at a maximum of 50°C. However, the lifespan of the product maybe reduced when operating continuously with a full load when the ambient temperature exceeds 40°C

## I/O Configuration

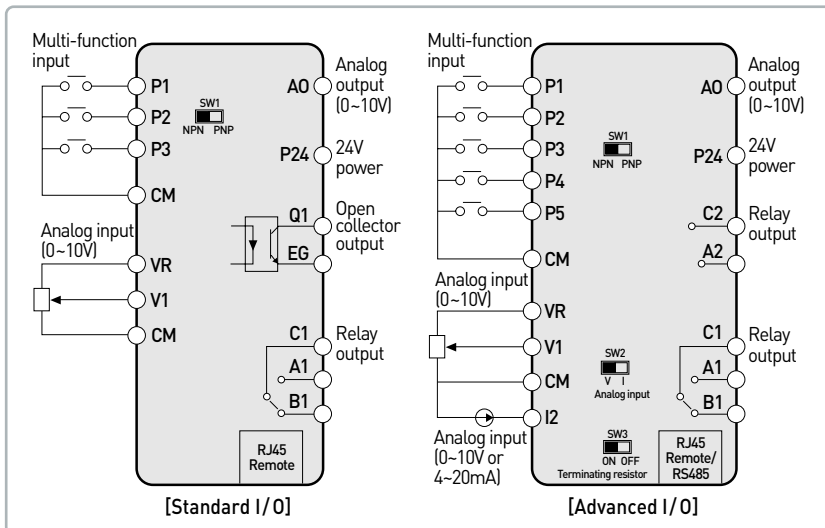

## Dimension

