

SANYU



Servo Drive System

Shanghai Sanyu Industry Co., Ltd

Content

Encoder and Driver	1
EtherCAT bus technology.....	2
SY200 series AC servo system.....	3
Label and specifications	4
Servo drive wiring picture	7
Standard wiring	8
Servo drive outline dimensional drawing.....	11
Motor specifications	13
Torque characteristics	17
Non-standard motor specifications	19
Power cable and encoder cable	21
Notice when using	23

*High precision,
High standard,
Provide customers with quality productions*



 :051-37133855-6

 :09014284236

WWW.ARCOKALA.COM

Encoder and driver

Encoder

- Driver support Line-saver type and absolute encoder. Line-saver type include 2500 line, 5000 line and so on; Absolute type support 17bit, 20bit, 23bit multi-turn encoder, max resolution ratio can reach 838 0000 line.
- Driver support self-learning from encoder angle, better match third party motor.
- Battery of multi-turn absolute encoder is easy to install and maintenance.

Driver characteristics

(1) Accurate positioning

- Max resolution ratio of absolute encoder can reach 23 bit, equal to 0.15 arc-second.
- Ethercat bus same step to clock $15\mu\text{s}$ same step to deviation $\pm 20\text{ns}$, same step vibrate.

① 117bit~23bit absolute encoder, resolution ratio reach 13 0000 line ~ 838 0000 line, can remember 65536 circle absolute position. Motor vibration is small, stable speed precision is high. Can be used for spots which ask for absolute position with precise positioning and high strength like robots, tapping center, servo turret, tricot machine, engraving and milling machine, millturn and so on ...

② Achieving precise synchronization by EtherCAT. Precise adjustment of EtherCAT distributed clock to achieve 300 node 120m distance, $15\mu\text{s}$ same step to deviation $\pm 20\text{ns}$, same step vibrate.

Can be used for printing machine, engraving and milling machine, die cutting machine, health equipment production line and so on ...

(2) Quick respond

- Response bandwidth of velocity loop can reach 1.3kHz.
- EtherCAT bus servo can support synchronous 100 axle within 1ms.

① Use quick respond driver to match low inertia and low torque fluctuation servo motor, system has high strength can better servo respond and shorten position adjusting time based on speed, torque feedforward control.

Can be used for high strength spots like engraving and milling machine, LED, SMT, die cutting machine, multi-wire cutting machine and so on.

② EtherCAT bus 100Mbps full-duplex communication, each axle have $1\mu\text{s}$ transmission delay, greatly improves the update time, Communication command which supported by driver dealing period shortest is $250\mu\text{s}$ (position mode) and $125\mu\text{s}$ (speed mode).

Can be used for applications which has high requirements for real-time like engraving and milling machine, printing machine.

(3) Easy to use and easy to maintenance

- Easy to install
- Easy to wire
- Self-adjustment for the system parameters
- EtherCAT bus support for more applications of long distance wiring distribution
- Absolute encoder battery maintenance is convenient

- Use of absolute encoder can omit limit and origin switch

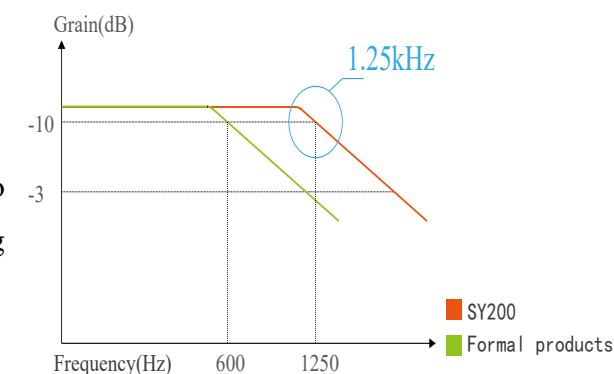
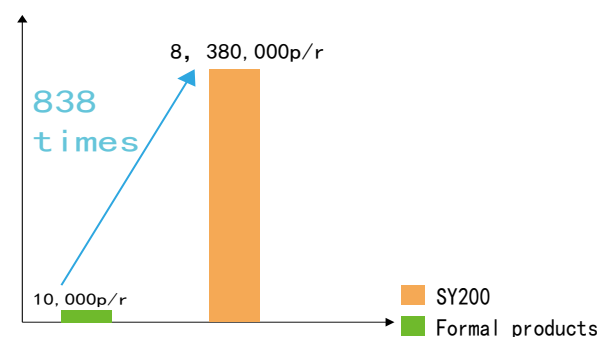

Example of arc interpolation

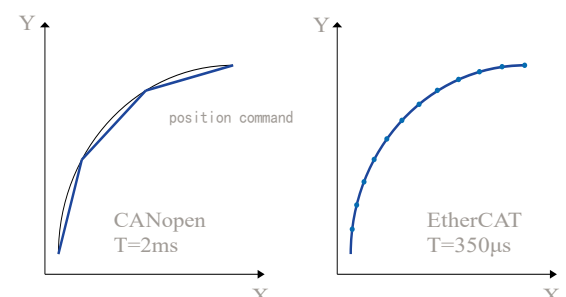

EtherCAT bus technology

- Developed by Germany Beckhoff company
- ETC(EtherCAT Technology Group) promote
- A totally opened ethernet protocol which used for control and automatic technology
- Under the voting to be ISO15745-4 standard
- EtherCAT is IEC specifications(IEC/PAS 62407)

EtherCAT protocol model

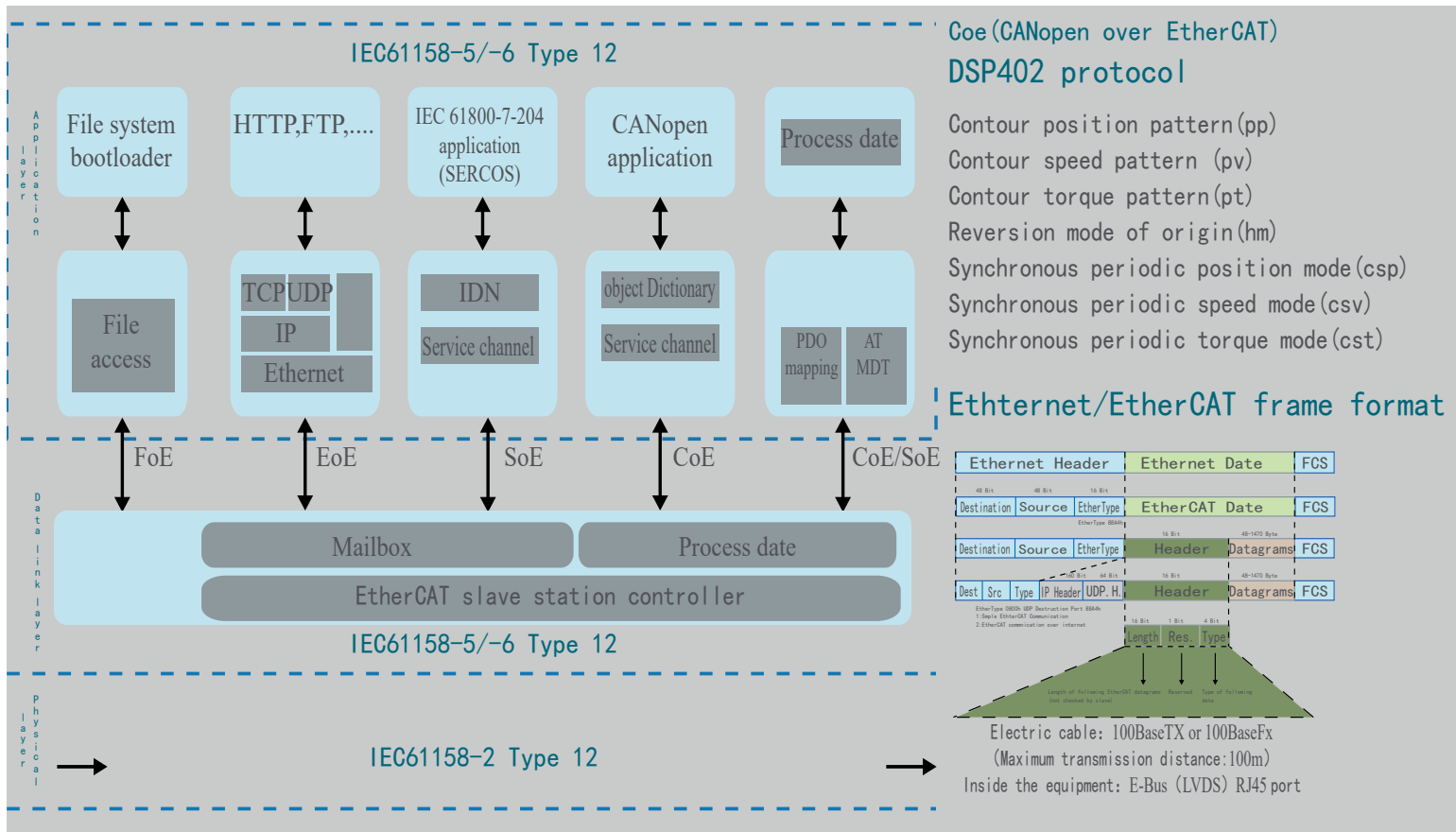

EtherCAT core technology

A frame to the end

- EtherCAT a frame to the end max data volume can reach 1470 bytes, data can be revised or added during message transfer, thus no need to storage place,buffer or combination / decomposition.
- Every node achieve calculate directly by hardware, do not need software in, reach minimum message delay. Time delay of 1 servo axle is just 1μs.

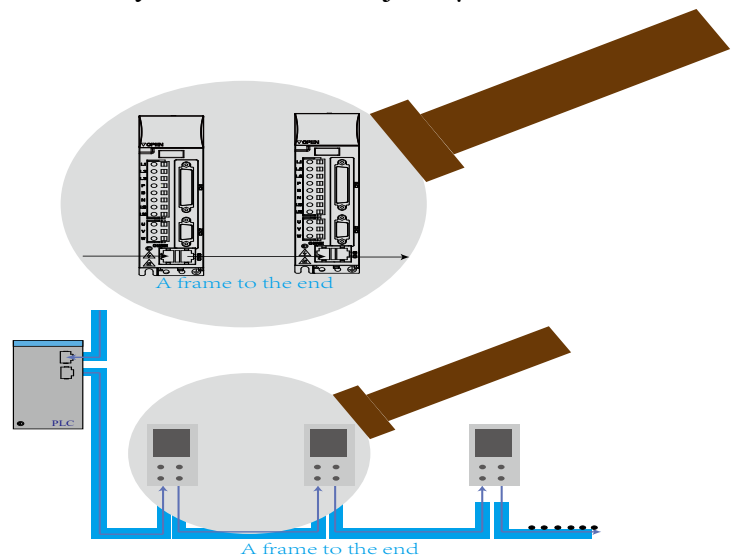

Same step clock

- Every EtherCAT slave station have clock mechanism in slave station contoleer ESC, called slave clock.
- Every EtherCAT master station inner side also have clock mechanism, called master station clock.
- EtherCAT network see the first slave station as reference clock, see reference clock as system clock of whole system, all clock including master station clock synchronization are take clock as reference.
- In EtherCAT network, clock distribution can make all Ethercat devises use same system time through synchronoussignal (SYNC signal), thus control every devices' task been executed synchronously.
- SYNC signal send cycle is synchronization cycle.

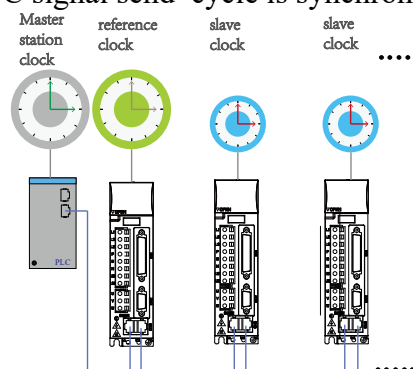

SY200 series AC servo system

Environmental safety

Improve environmental safety

- SY servo motor meet IP65 standard (except Through axle part) (Notice 2)



Meet EN, UL, cUL standard

- SY200 series standard version meet overseas standard.



Disturbance rejection function

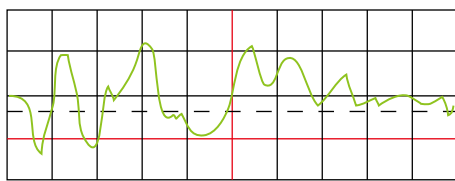

Other motor

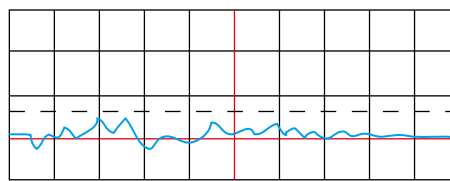

SY motor

Other characteristics

Servo amplifier

- Compared with other model, install size decrease 40%. (compared with 400W)

Unit: mm

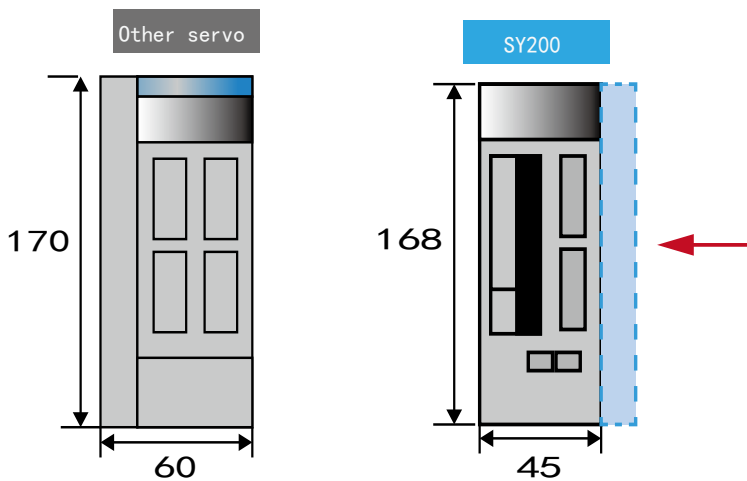

- Save wire

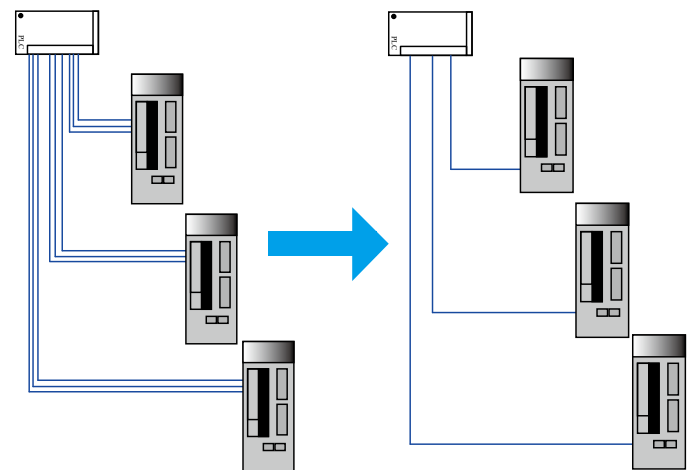

Servo Motor

- Max rotary speed can support 5000rpm
- Miniaturization and light weight
- Power range: 100W~7.5kW
- Low inertia
- Small power (2kw and below) is 3 times overload, medium and big power (2kw above) is 2.5 times overload.
- cogging torque / rated torque 1%
- Fully closed self cooling, levels of protection IP65 (except Shaft revolving part, front section of wire)
- With high resolution encoder, low backlash brake
- Continuous work
- Insulation class F level
- Vibration class V15
- Install way of flange

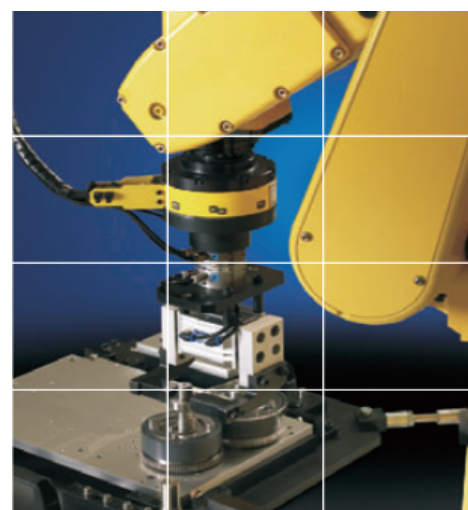

Label

Servo drive

Model: $\frac{\text{SY200-40A-2}}{\text{① ② ③ ④}}$ (00)

- ① **SY200**: SY200 series
- ② **Drive power**: 40A:400W; 75A:750W; 100A:1kW; 150A:1.5kW; 200A:2kW; 300A:3kW; 450A:4.5kW; 550A:5kW; 750A:7.5kW
- ③ **Drive voltage class**: 2:1PH/3PH AC220V; 4:3PH AC380V
- ④ **Software model**: 00:General used; 01:ECAM; 02:EtherCAT bus;

Servo motor

Model: $\frac{\text{SY-60 KP 40A 30 D A Y Y B}}{\text{① ② ③ ④ ⑤ ⑥ ⑦ ⑧ ⑨ ⑩}}$

- ① **SANYU drive**
- ② **(Flange)**: 60:60 flange; 80:80 flange; 130:130 flange; 180:180 flange
- ③ **Motor series**: KP:Low inertia; SP:Medium inertia; HP:High inertia;
- ④ **Motor power**: 40A:400W; 75A:750W; 100A:1KW;
- ⑤ **Motor rotary speed**: 10:1000rpm; 15:1500rpm; 20:2000rpm; 25:2500rpm; 30:3000rpm;
- ⑥ **Encoder model**: D:17 bit; T:2500 line; P:23 bit;
- ⑦ **Electromagnetic brake (brake)**: A:Without brake; B:With brake
- ⑧ **Key groove**: Y:Have key groove;
- ⑨ **Oil seal**: Y:Have oil seal;
- ⑩ **Voltage class**: B:220V; D:380V;

Drive technical specifications

Working current of servo drive

Servo drive model	Voltage class(V)	Rated power(kW)	Rated output current (A)
SY200-20A-2	1PH-220	0.2	1.6
SY200-40A-2	1PH-220	0.4	2.8
SY200-75A-2	1PH/3PH-220	0.8	5.5
SY200-100A-2	3PH-220	1.0	7.6
SY200-150A-2	3PH-220	1.5	9.6
SY200-200A-2	3PH-220	2.0	11.6
SY200-200A-4	3PH-380	2.0	6.0
SY200-300A-4	3PH-380	3.0	9.0
SY200-450A-4	3PH-380	4.5	12.9
SY200-550A-4	3PH-380	5.5	16.5
SY200-750A-4	3PH-380	7.5	25.7

Labels and Specifications

■ EtherCAT type servo drive general -used specifications

Basic specifications	Control method		1. Position control 2. Speed control 3. Torque control	
	Feedback type		1. Square wave increment type 2. Absolute value	
	Using conditions	Using/Storage temperature	0~+55°C/-20~+85°C	
		Using/Storage humidity	90%RH below (will not have condensation)	
Strength of Vibration		4.9m/s ² /19.6m/s ²		
Torque speed instruction	Performance	Speed controlling range	1:5000 (The bottom limit of speed controlling range is the condition of non-stop when rated torque overload)	
		Speed change rate	Load change	When 0~100% load: ±0.01% below (under the rated rotary speed)
			Voltage change rate	Rated voltage ±10%: 0% (under the rated rotary speed)
			Temperature change rate	25±25°C: ±0.1% below (under the rated rotary speed)
		Frequency characteristics	1.3KHz (when J L = J M)	
		Torque control precision	±2%	
		Soft start time setting	0 ~ 65s(can separate set acceleration and deceleration time)	
	Input signal	Speed instruction input	Instructed voltage	DC±10V(0V ~ ±10V: alterable setting range)/rated rotary speed Input voltage: max±12V(motor FWD when positive order)
			Input impedance	About 10kΩ
			Circuit time parameters	About 47μs
Torque instruction input		Instructed voltage	DC±10V(0V ~ ±10V: alterable setting range)/rated rotary speed Input voltage: max±12V(FWD torque instruction when positive instruction)	
		Input impedance	About 10kΩ	
		Circuit time parameters	About 47μs	
Torque speed	Rotation direction	Use DI signal input		
Position of position control mode	Performance	Feedforward compensation	0~100% (set resolution ratio 1%)	
		Positioning complete width	1~65535 instruction unit (set resolution ratio 1 instruction unit)	
	Encoder	Incremental	2500 Line, 5000 Line Provincial line	
Input output signal	Position signal	Output form	A phase 、 B phase 、 Z phase	
		Frequency division ratio	Arbitrary	
	Sequential input signal	Can make changes in signal distribution	Line 8 DI servo on, P action (or control mode swift, make motor swift in FWD/REV by internal setted speed, Zero clamping, forbid instruction pulse). Positive side current limit, reverse side current limit (or internal speed choose)	
	Sequential output	Can make changes in signal distribution	Line 3 DO include positioning complete (same speed), motor under rotation, servo be all set, current under limit, speed under limit	
Internal function	Dynamic brake (DB) function		Main power OFF、 servo alarm、 servo OFF、 Overshoot action	
	Overrange (OT) prevention function		When P-OT, N-OT action, DB stop, deceleration to stop or Inertial operation to stop	
	Electronic Gearing		0.001≤B/A≤4000	
	Defensive function		Over-current, over-voltage, low-voltage, overload, htteroplasia, abnormity of main circuit detection unit, heat sink overheating, power supply phase loss, spillover and overspeed, enocder abnormal, prevent loss of control, abnormal CPU, abnormal parameter, and so on...	
	LED display function		Main power CHARGE, 5 bit LED display	
	Communication function	Connection device	EtherCAT, MODBUS	
		Axis address setting	Setted as per user parameters	
		Function	MODBUS: Status display, user parameters setting, monitor display, alarm follow display, JOG operation and automatic tuning, Surveying and mapping function	
Others		Origin retrieval, motor angle self-learning function, gain self adjustment, low-frequency vibration restrain, operation mode swift, motor resonance restrain, rich DIDO function, all close-loop		

Pulse type servo drive general-used specifications

Basic specifications	Control method		1. Position control 2. Speed control 3. Torque control	
	Feedback type		1. Square wave increment type 2. Absolute value	
	Using conditions	Using/Storage temperature	0~+55°C/-20~+85°C	
		Using/Storage humidity	90%RH below (will not have condensation)	
Strength of Vibration resistance /		4.9m/s ² /19.6m/s ²		
Torque speed instruction	Performance	Speed controlling range		1:5000 (The bottom limit of speed controlling range is the condition of non-stop when rated torque overload)
		Speed change rate	Load change rate	When 0~100% load: ±0.01% below (under the rated rotary speed)
			Voltage change rate	Rated voltage ±10%: 0% (under the rated rotary speed)
			Temperature change rate	25±25°C: ±0.1% below (under the rated rotary speed)
		Frequency characteristics (bandwidth)		1.3KHz (when J L = J M)
	Torque control precision		±2%	
	Soft start time setting		0 ~ 65s(can separate set acceleration and deceleration time)	
	Input signal	Speed instruction input	Instructed voltage	DC±10V(0V ~ ±10V: alterable setting range)/rated rotary speed Input voltage: max±12V(motor FWD when positive order)
			Input impedance	About 10kΩ
			Circuit time parameters	About 47μs
Torque instruction input		Instructed voltage	DC±10V(0V ~ ±10V: alterable setting range)/rated rotary speed Input voltage: max±12V(FWD torque instruction when positive instruction)	
		Input impedance	About 10kΩ	
	Circuit time parameters	About 47μs		
Torque speed	Rotation direction	Use DI signal input		
Position of position control mode	Performance	Feedforward compensation		0~100% (set resolution ratio 1%)
		Positioning complete width setting		1~65535 instruction unit (set resolution ratio 1 instruction unit)
	Encoder	Incremental		2500 Line, 5000 Line Provincial line
		Absolute		17 bit, 20 bit, 23 bit
	Input signal	command pulse	Input pulse type	1. Symbol + pulse column 2. .CCW+CW pulse column 3.90 ° phase difference 2 phase pulse (A phase+B phase)
			Input pulse shape	Differential drive: Max is 4Mpps
Input pulse frequency			Open-collector drive: Max is 500kps	
Controlling signal		Delete signal (input pulse shape same as command pulse)		
Input output signal	Position signal	Output form		A phase、B phase、Z phase
		Frequency division ratio		Arbitrary
		Sequential input signal	Can make changes in signal distribution	Line 9 DI servo on, P action (or control mode swift, make motor swift in FWD/REV by internal setted speed,Zero clamping, forbid instruction pulse).Positive side current limit, reverse side current limit (or internal speed choose)
	Sequential output signal	Can make changes in signal distribution	Line 8 DO include positioning complete (same speed), motor under rotation, servo be all set, current under limit, speed under limit	
Internal function	Dynamic brake (DB) function		Main power OFF、 servo alarm、 servo OFF、 Overshoot action	
	Overrange (OT) prevention function		When P-OT, N-OT action, DB stop, deceleration to stop or Inertial operation to stop	
	Electronic Gearing		0.001 ≤ B/A ≤ 4000	
	Defensive function		Over-current, over-voltage, low-voltage, overload, hteroplasia, abnormality of main circuit detection unit, heat sink overheating, power supply phase loss, spillover and overspeed, enocder abnormal, prevent loss of control, abnormal CPU, abnormal parameter, and so on...	
	LED display function		Main power CHARGE, 5 bit LED display	
	Communication function	Connection device	CAN (optional), MODBUS	
		Axis address setting	Setted as per user parameters	
		1: N communication	When RS-485 port, biggest slave station is decided by master station supported quantity	
Function		MODBUS: Status display, user parameters setting, monitor display, alarm follow display, JOG operation and automatic tuning, Surveying and mapping function		
Others		Origin retrieval, motor angle self-learning function,gain self adjustment,low-frequency vibration restrain, operation mode swift, motor resonance restrain, rich DIDO function, all close-loop		

Servo drive wiring picture

Drive system wiring picture

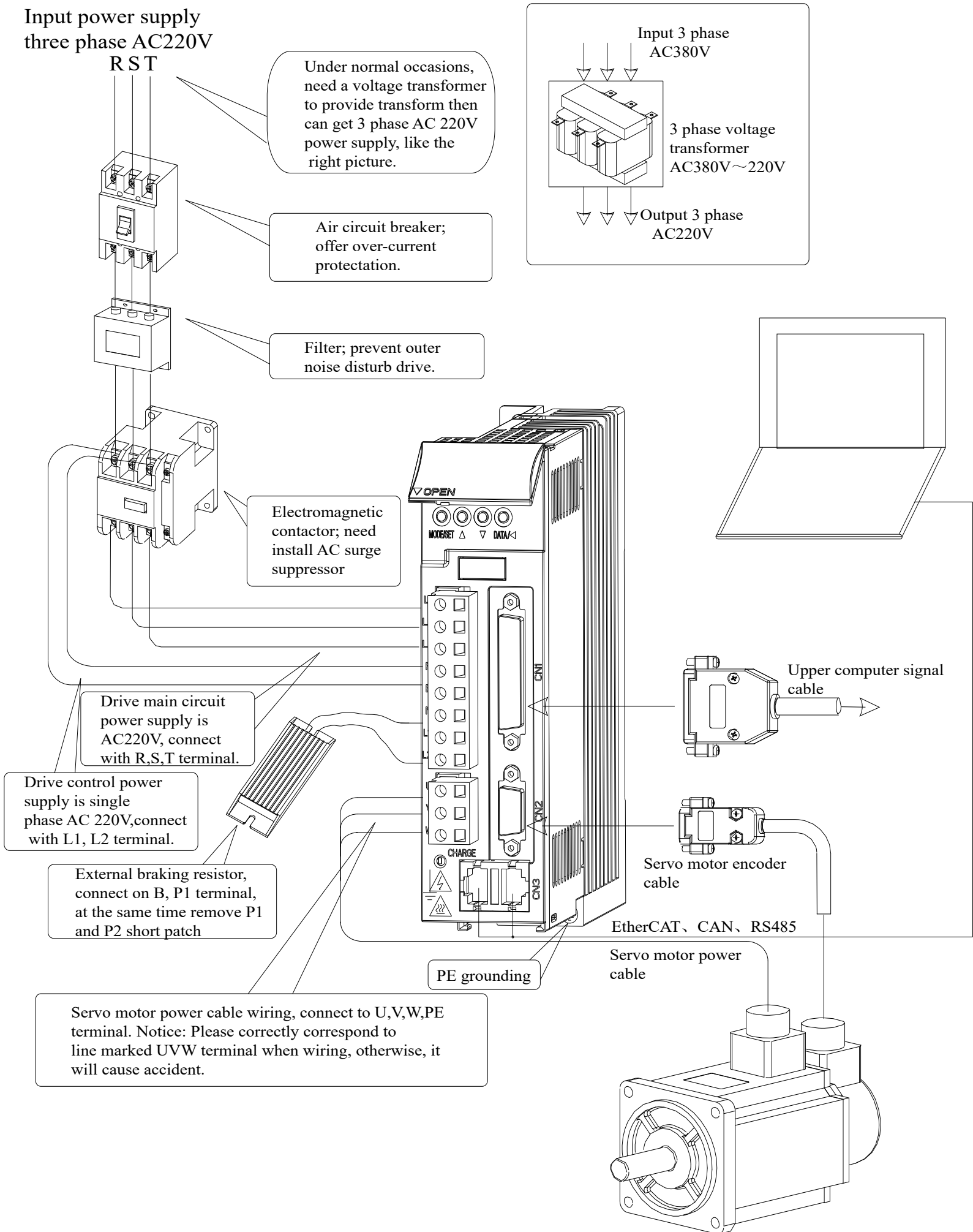

Control method standard wiring diagram

Position control mode

(0.2-3kW)

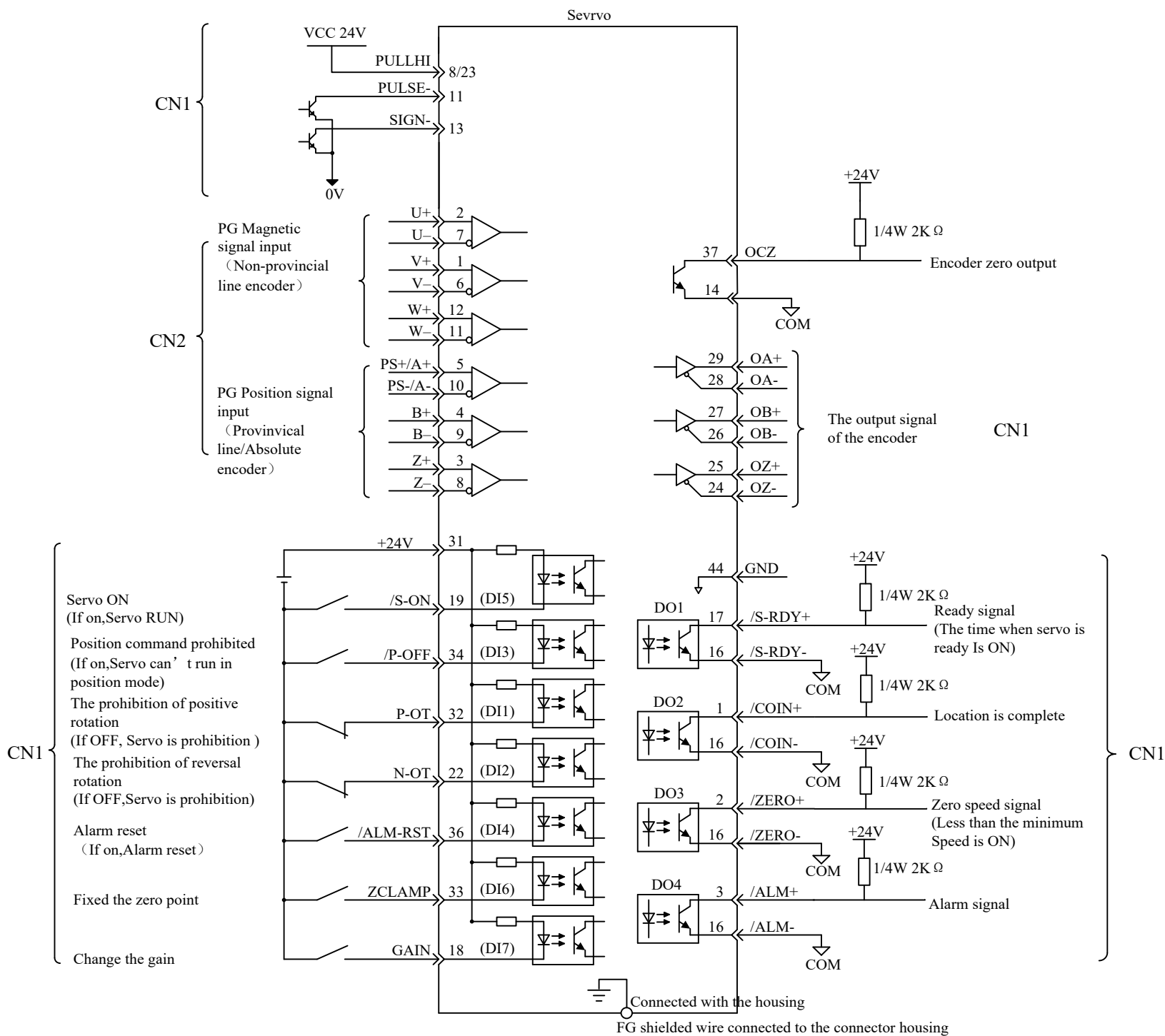

Standard wiring diagram

Speed control mode

(0.2-3kW)

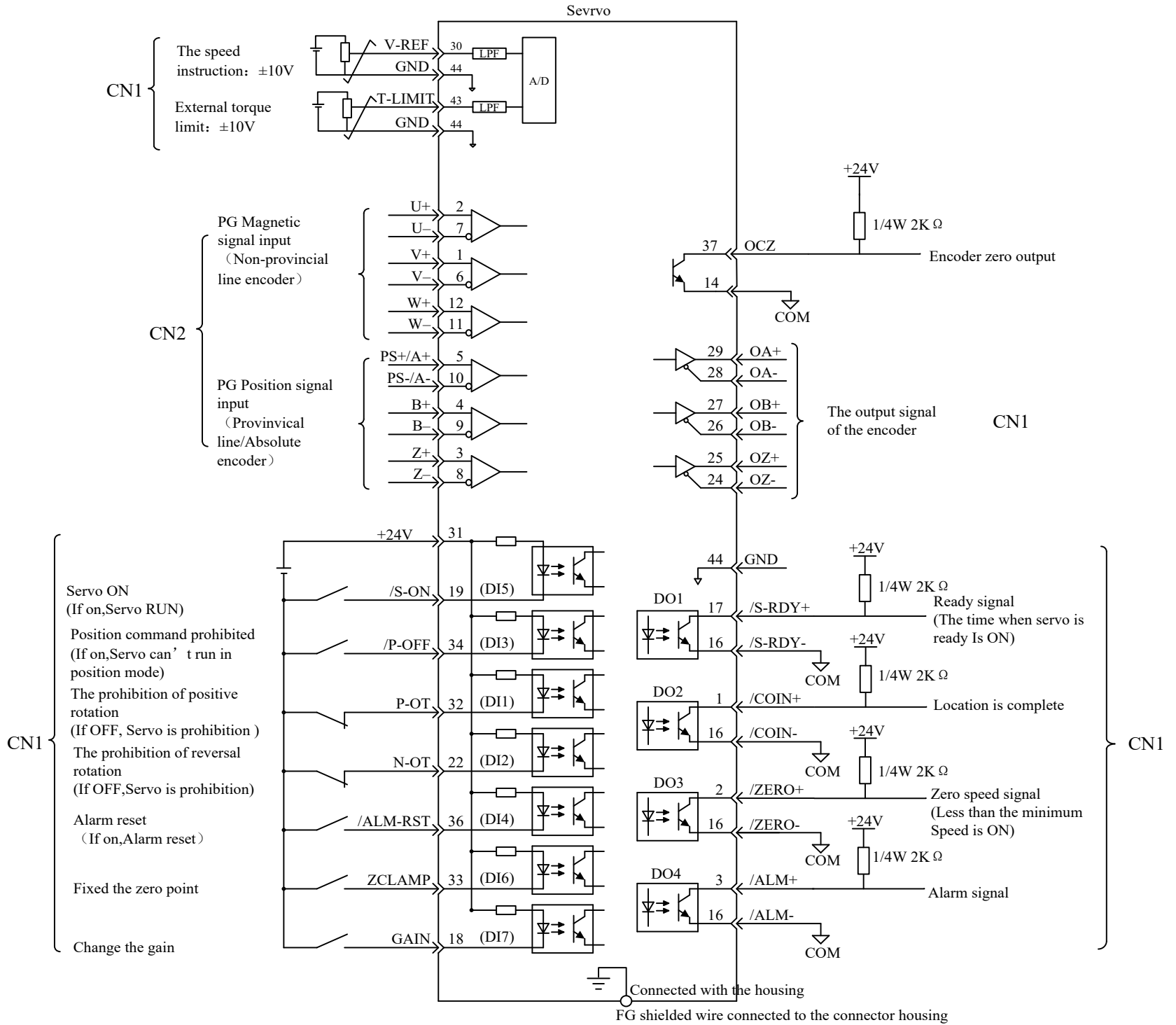

Standard wiring diagram

Torque control mode

(0.2-3kW)

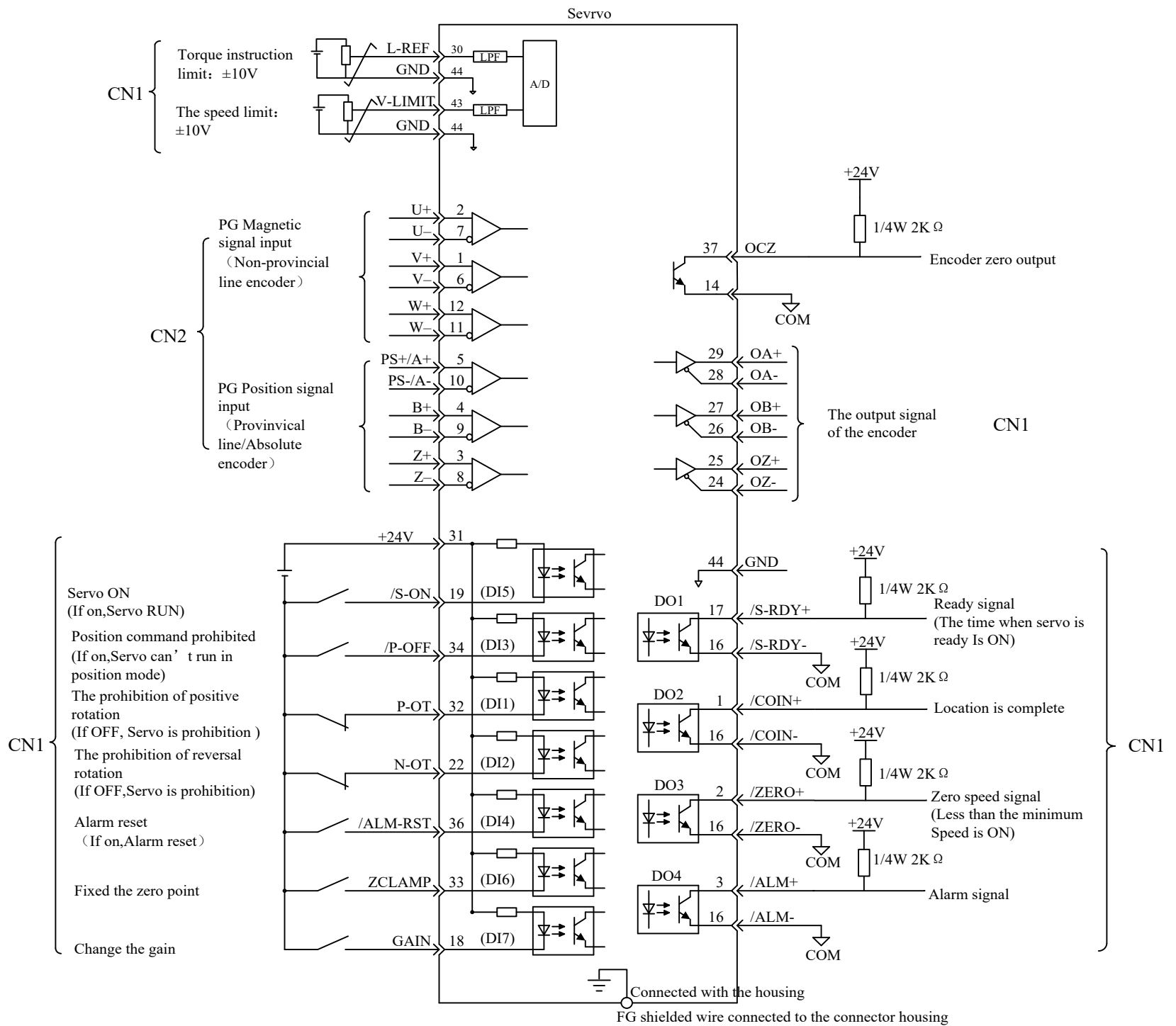

Servo driver dimensions

Installation size A、B

- Suitable model: 750W and following
H×D×W=168x168x45mm

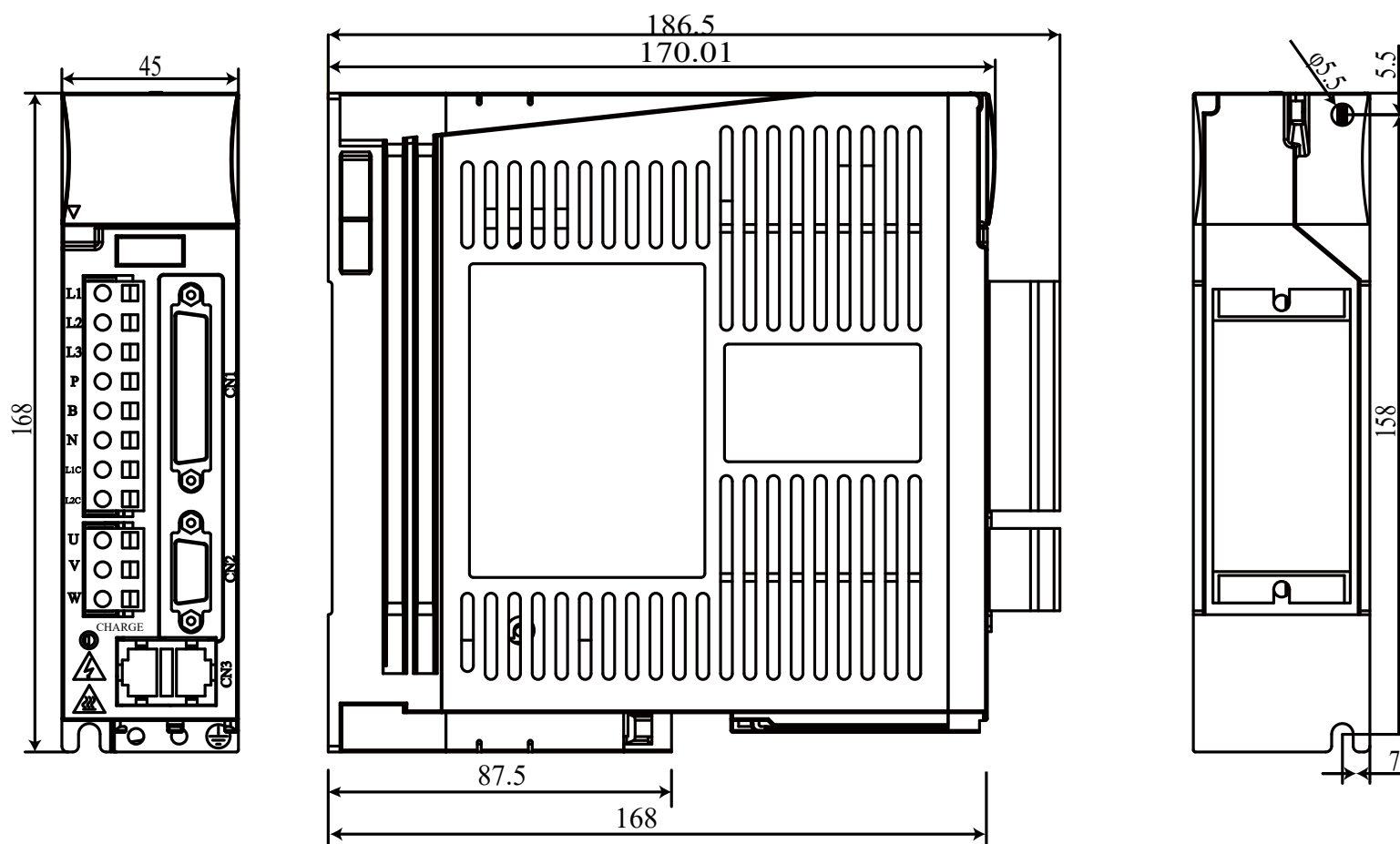

- Suitable models: 220V 1KW-2KW 380V 2KW-3KW
H×D×W=168x168x70mm

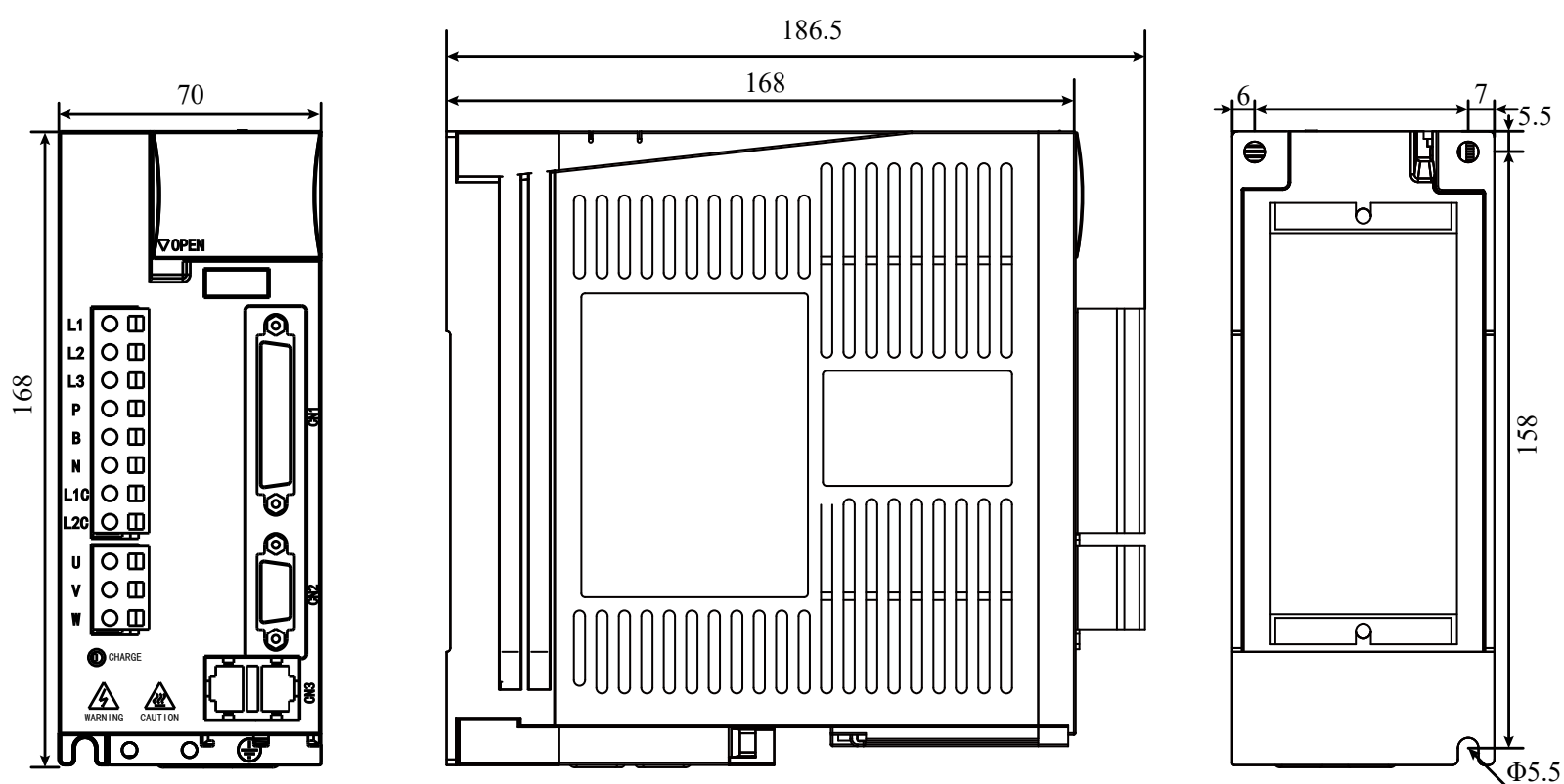

Installation size C, D

- Suitable model: 380V 4.5KW-5.5KW
H×D×W=260x200x88.5mm

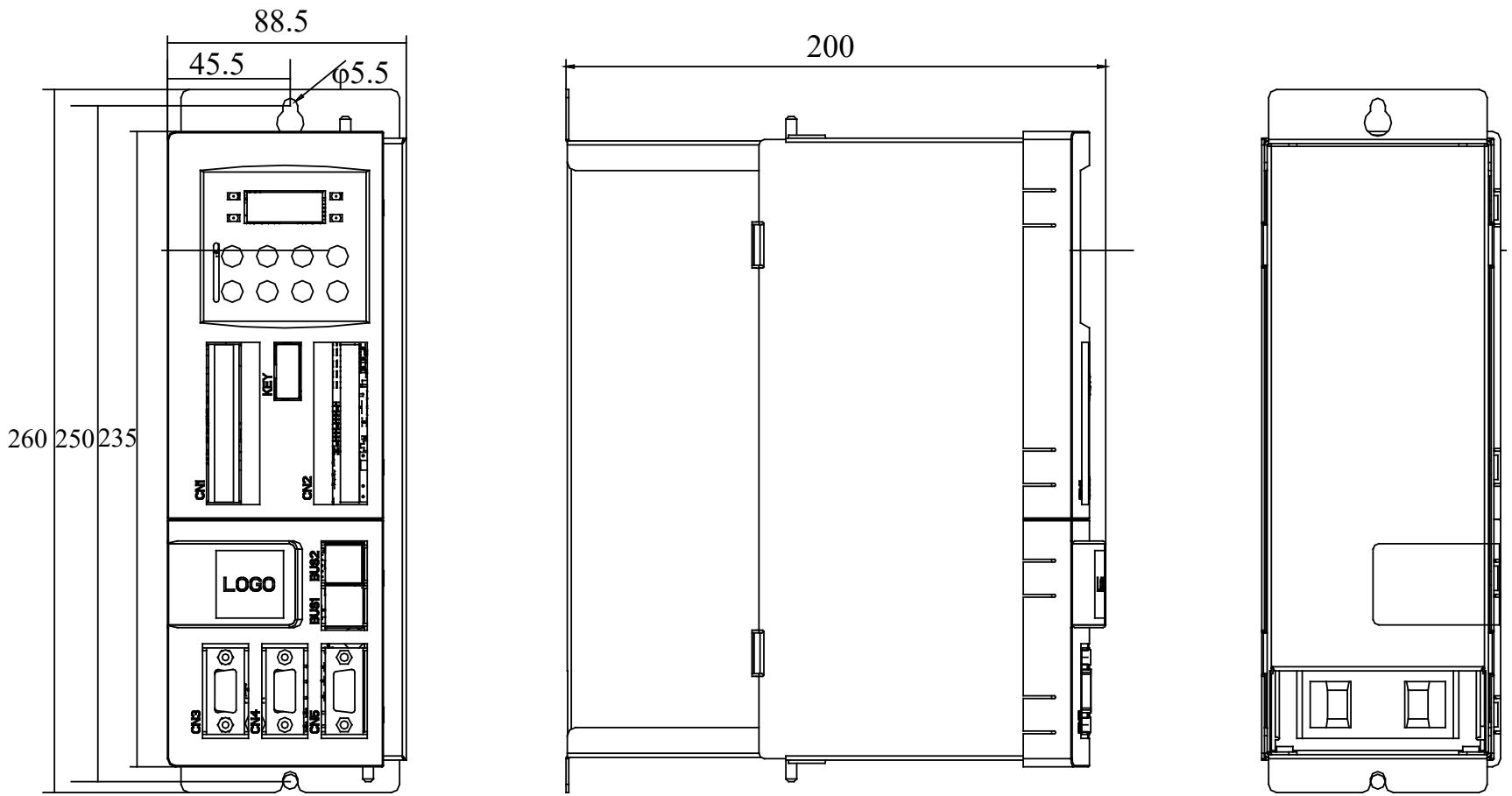

- Suitable model: 380V 7.5KW-11KW
H×D×W=290x202x135.5mm

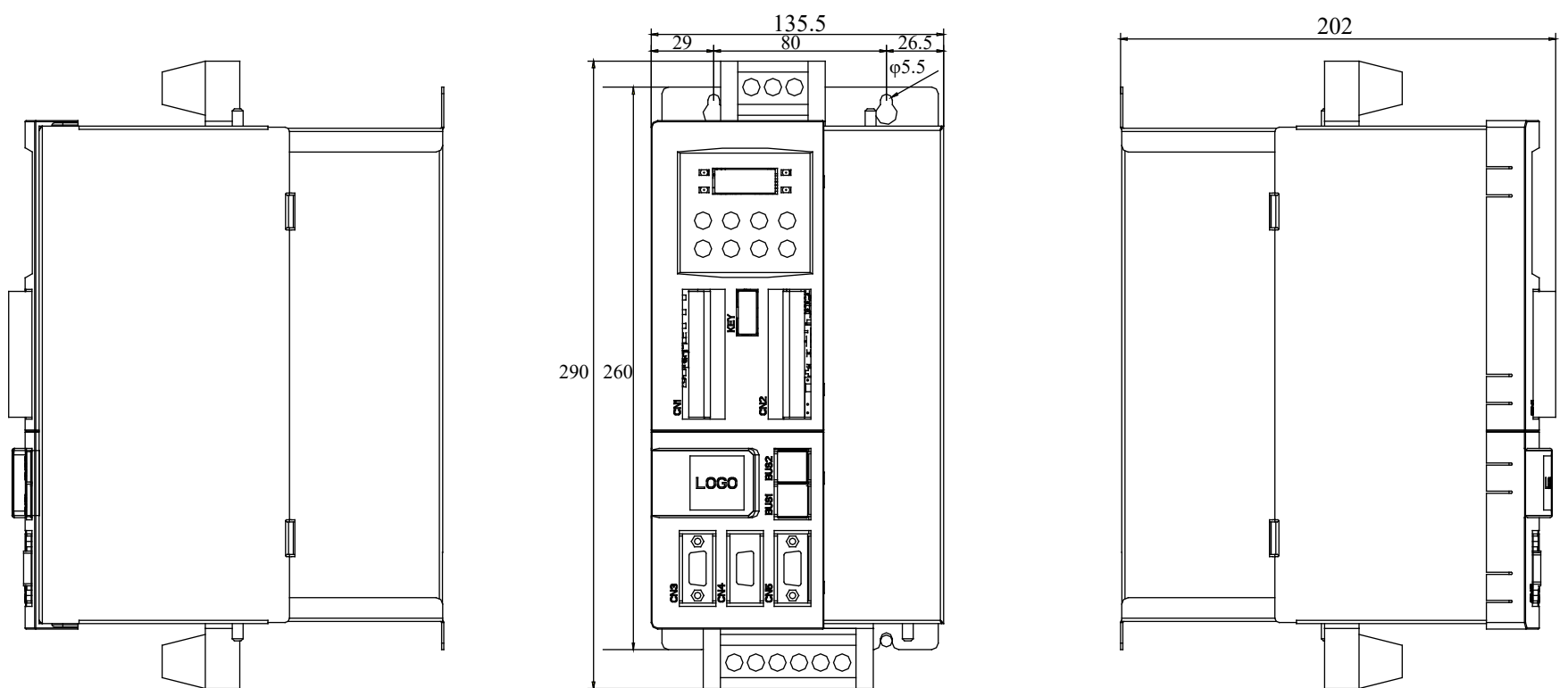

Motor specifications

60 base series

Motor model	Rated power(kW)	Rated line voltage(V)	Rated line Current(A)	Rated speed(rpm)	Rated torque(N·M)	Max rated torque(N·M)	Rotor inertia(Kg·M ²)
SY-60KP20A30□□YYB	0.2	220	1.3	3000	0.64	1.91	0.0264×10^{-3}
SY-60KP40A30□□YYB	0.4	220	2.6	3000	1.3	3.8	0.028×10^{-3}

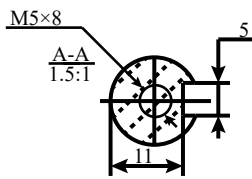
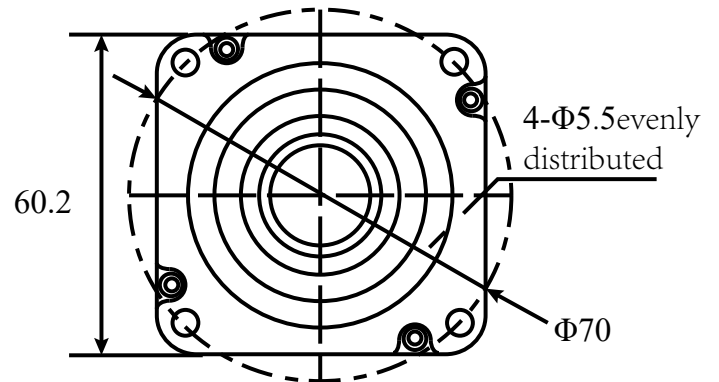
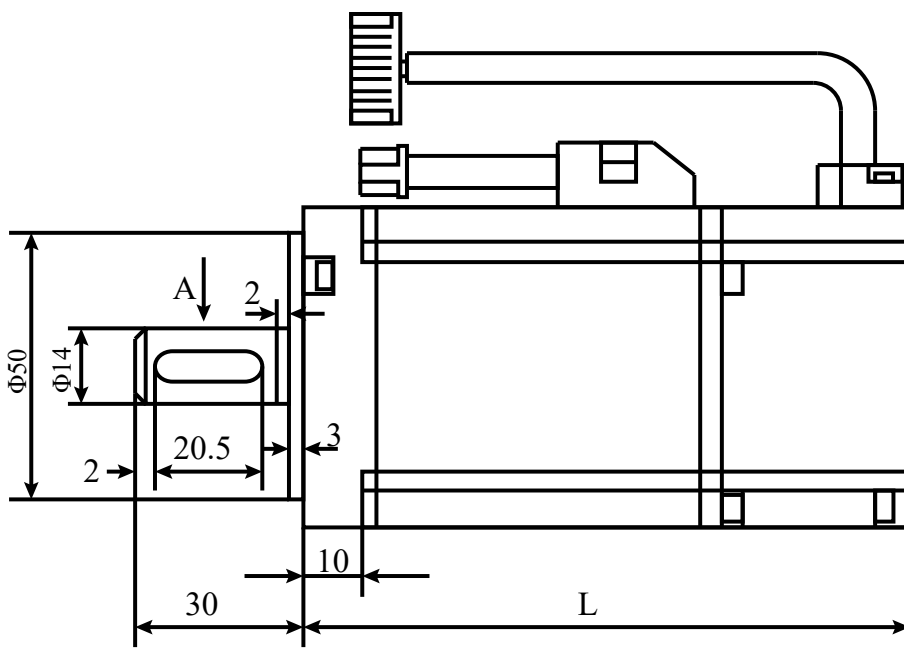

ARCO CONTROL

☎ :051-37133855-6

💬 :09014284236

WWW.ARCOKALA.COM

Mode	SY-60KP20A30	SY-60KP40A30
Without brake size(L)	109	135

Motor specifications

80 base series

Motor model	Rated power(kW)	Rated line voltage(V)	Rated line Current(A)	Rated speed(rpm)	Rated torque(N·M)	Max torque(N·M)	Rotor inertia(Kg·M ²)
SY-80KP40A30□□YYB	0.4	220	2.0	3000	1.27	3.8	1.05×10^{-4}
SY-80KP75A30□□YYB	0.75	220	4.4	3000	2.39	7.16	0.9×10^{-4}
SY-80KP73A20□□YYB	0.73	220	3.0	2000	3.50	10.5	2.63×10^{-4}
SY-80KP100A25□□YYB	1	220	4.4	2500	4.00	12	2.97×10^{-4}

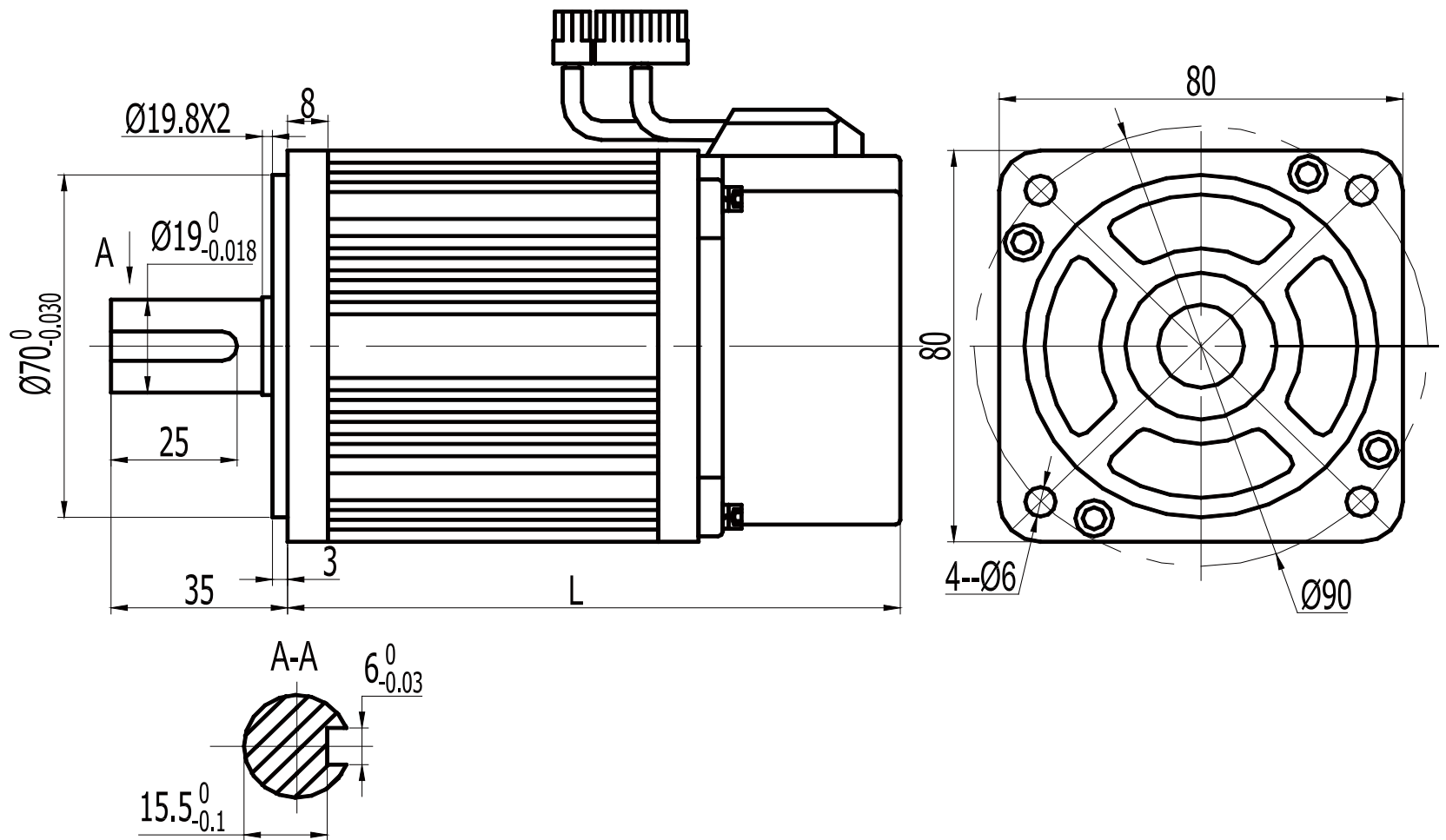

Mode	SY-80KP40A30	SY-80KP73A20	SY-80KP75A30	SY-80KP100A25
Without brake size(L)	124	179	162.5	191

Motor specifications

130 base series

Motor model	Rated power(kW)	Rated line voltage(V)	Rated line Current(A)	Rated speed(rpm)	Rated torque(N·M)	Max torque(N·M)	Rotor inertia(Kg·M ²)
SY-130SP100A25□□YYB	1.0	220	4.0	2500	4.0	12	0.85×10^{-3}
SY-130SP100A20□□YYB	1.0	220	5.0	2000	5.0	15	1.06×10^{-3}
SY-130SP150A15□□YYB	1.5	220	6.0	1500	10.0	25	1.94×10^{-3}
SY-130SP150A20□□YYB	1.5	220	7.5	2000	7.7	22	1.53×10^{-3}
SY-130SP150A25□□YYB	1.5	220	6.0	2500	6.0	18	1.26×10^{-3}
SY-130SP200A20□□YYB	2.0	220	10.0	2000	10.0	25	1.94×10^{-3}
SY-130SP200A25□□YYB	2.0	220	7.5	2500	7.7	22	1.53×10^{-3}
SY-130SP200A20□□YYD	2.0	380	6.0	2000	10.0	30	2.77×10^{-3}
SY-130SP200A25□□YYD	2.0	380	6.0	2500	10.0	25	1.94×10^{-3}
SY-130SP380A25□□YYD	3.8	380	8.8	2500	15.0	30	2.77×10^{-3}

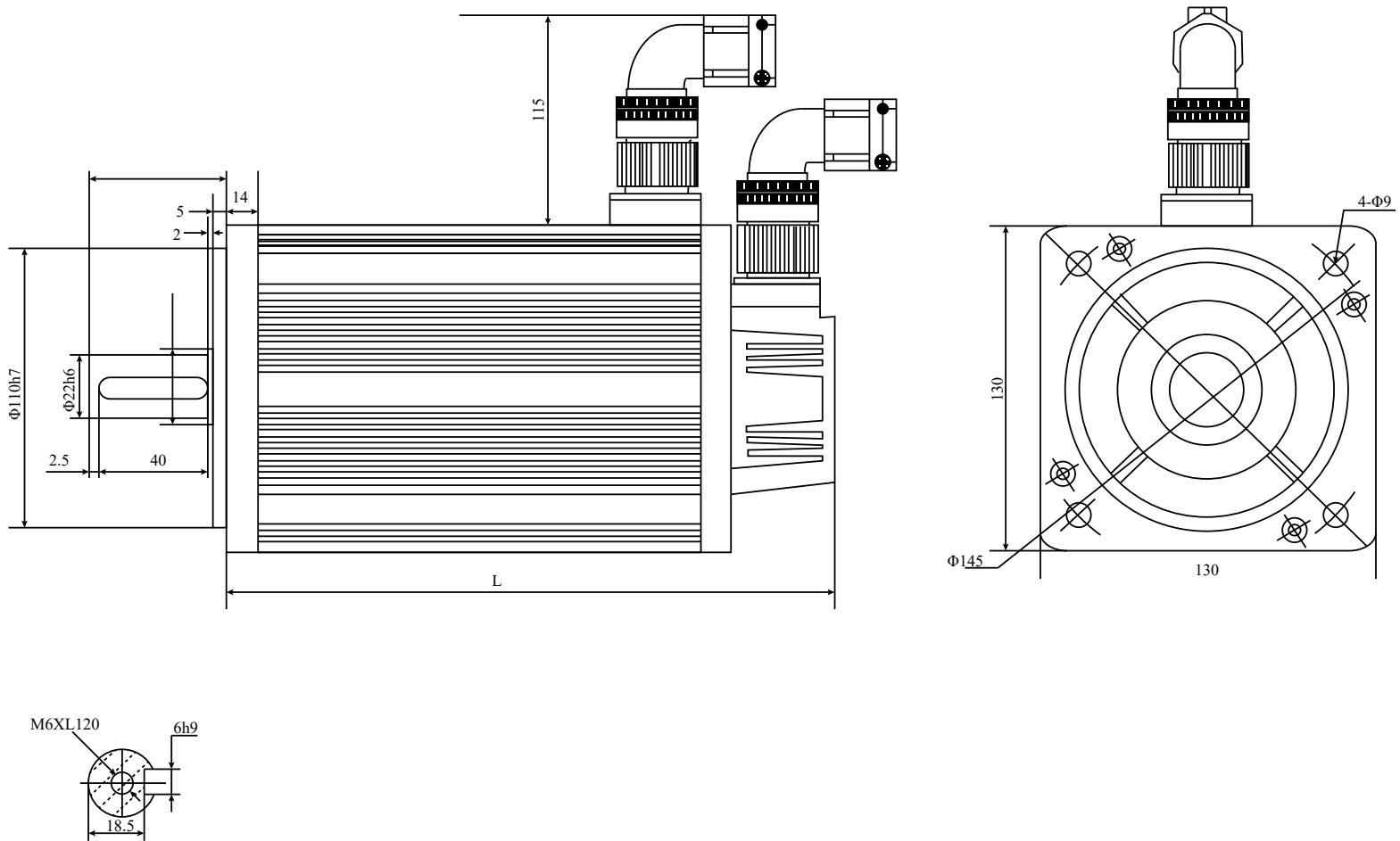

Rated torque(N·M)	130 series						
	4	5	6	7.7	10		15
					1500rpm	2500rpm	2500rpm
Without brake(mm)	166	171	179	192	213	209	231
With electronic brake(mm)	229	234	242	255	294	290	312

180 base series

Motor model	Rated power(kW)	Rated line voltage(V)	Rated line Current(A)	Rated speed(rpm)	Rated torque(N·M)	Max torque(N·M)	Rotor inertia(Kg·M ²)
SY-180SP300A15□□YYD	3.0	380	7.5	1500	19.0	47	7.0×10^{-3}
SY-180SP400A15□□YYD	4.0	380	10.0	1500	25.5	62	9.64×10^{-3}
SY-180SP450A20□□YYD	4.5	380	9.5	2000	21.5	53	7.96×10^{-3}
SY-180SP450A15□□YYD	4.5	380	10.0	1500	28.0	69	9.64×10^{-3}
SY-180SP550A15□□YYD	5.5	380	12.0	1500	35.0	70	12.25×10^{-3}
SY-180SP750A15□□YYD	7.5	380	20.0	1500	48.0	96	16.72×10^{-3}

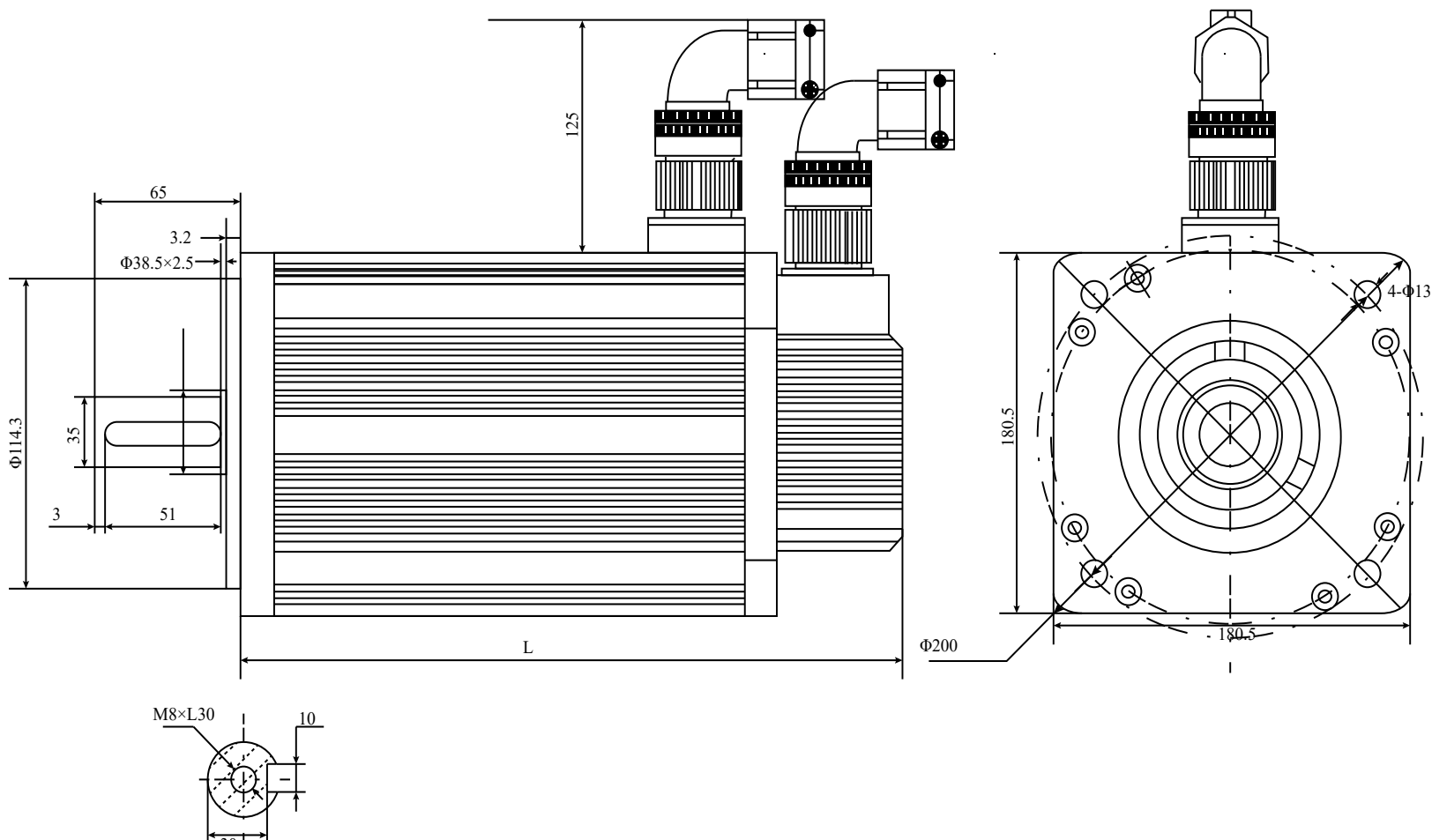

	180 series					
Rated torque(N·M)	19	21.5	25.5	28	35	48
Without brake(mm)	232	243	262	262	292	346
With electronic brake(mm)	304	315	334	334	364	418

Torque characteristic curve

60 base series

60 base 200w3000rpm

Torque (N·m)

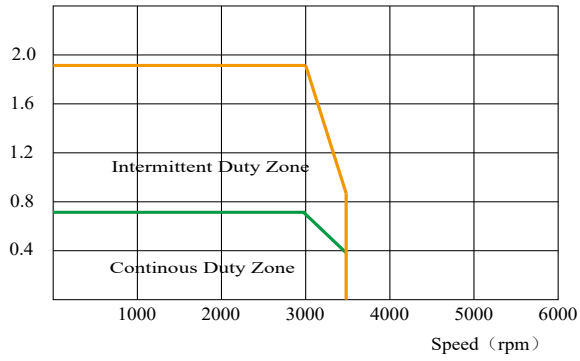

60 base 400w3000rpm

Torque (N·m)



80 base series

80 base 400w3000rpm

Torque (N·m)

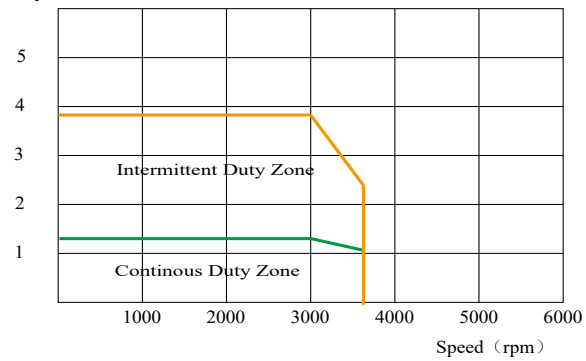

80 base 750w3000rpm

Torque (N·m)

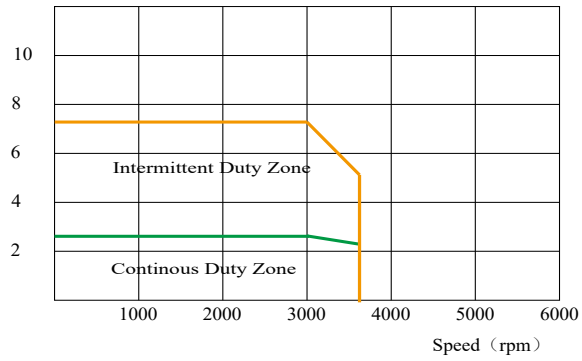

80 base 730w2000rpm

Torque (N·m)

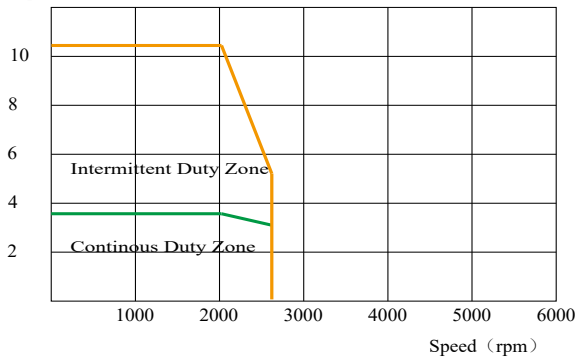

80 base 1000w2500rpm

Torque (N·m)

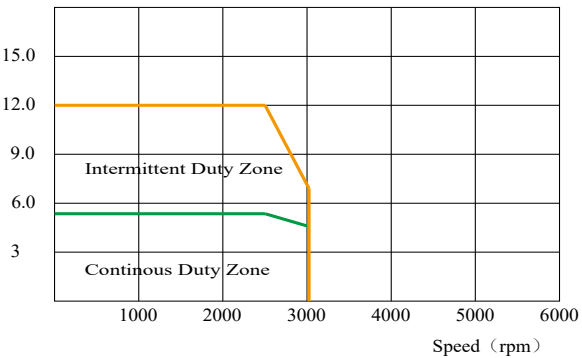

130 base series

130 base 1000w2500rpm

Torque (N·m)



130 base 1000w2000rpm

Torque (N·m)

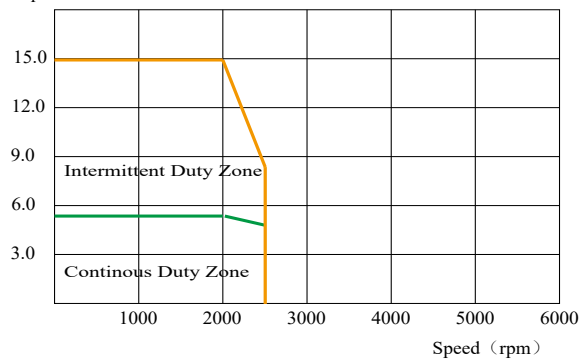

130 base 1500w1500rpm

Torque (N·m)

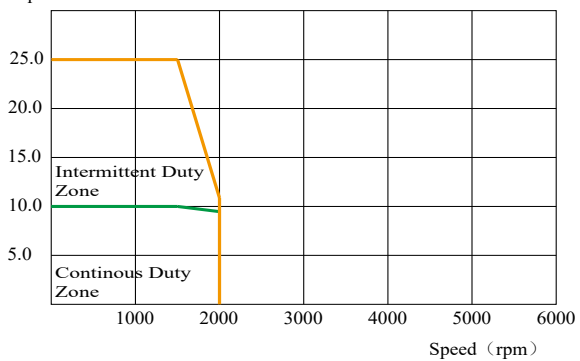

130 base 1500w2000rpm

Torque (N·m)

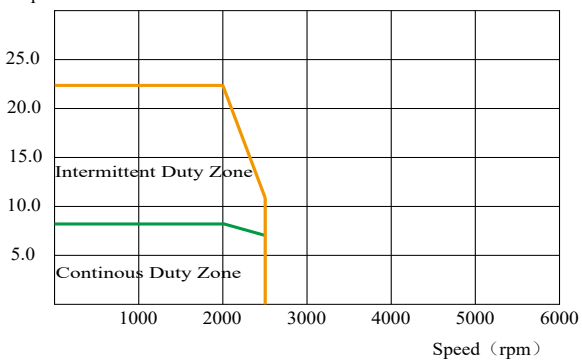

130 base series

130 base 1500w2500rpm

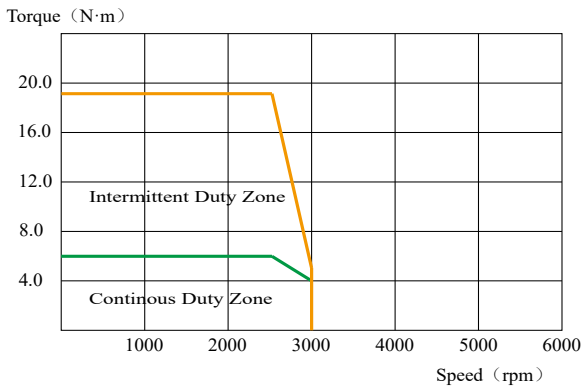

130 base 2000w2000rpm (220v)

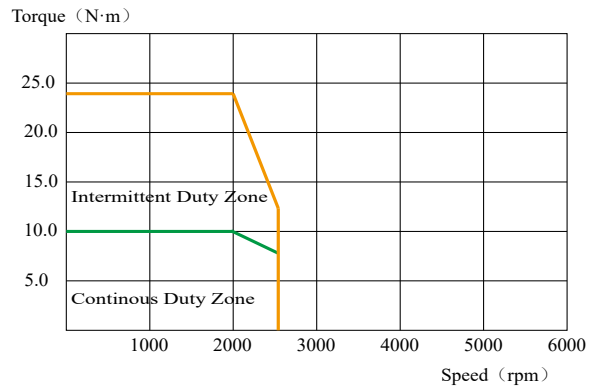

130 base 2000w2500rpm (220v)

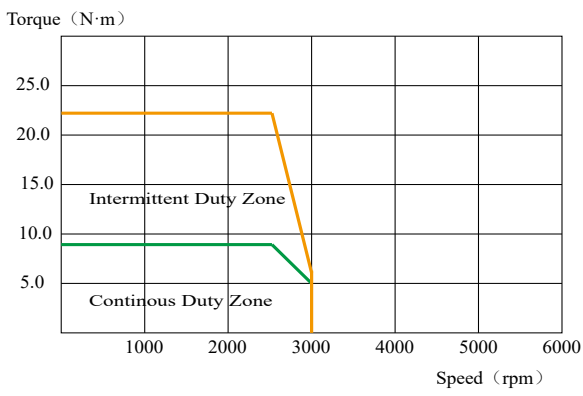

130 base 2000w2000rpm (380v)

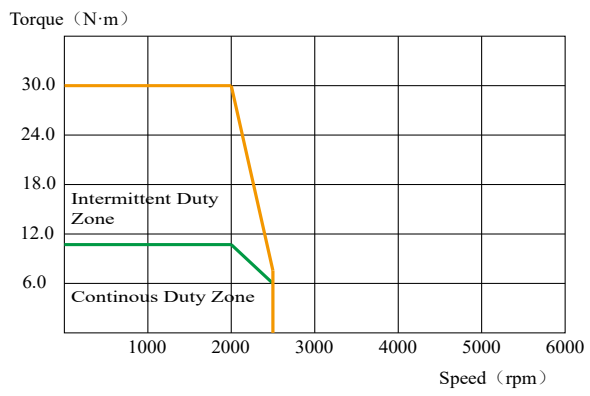

130 base 2000w2500rpm (380v)

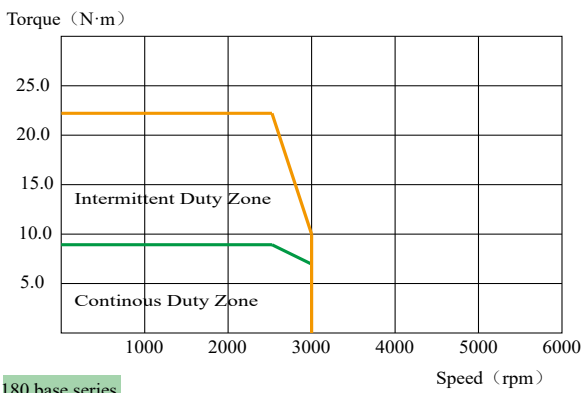

130 bases 3800w2500rpm (380v)

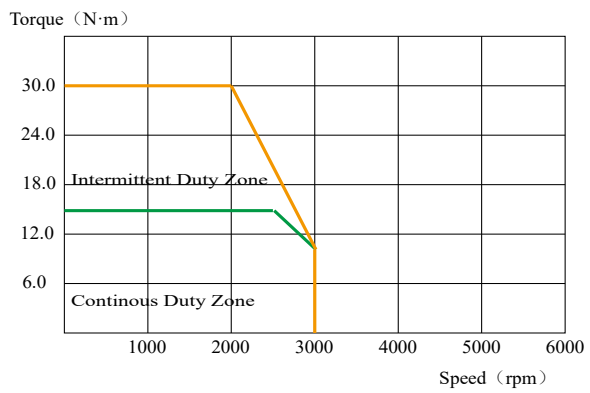

180 base series

180 base 3000w1500rpm

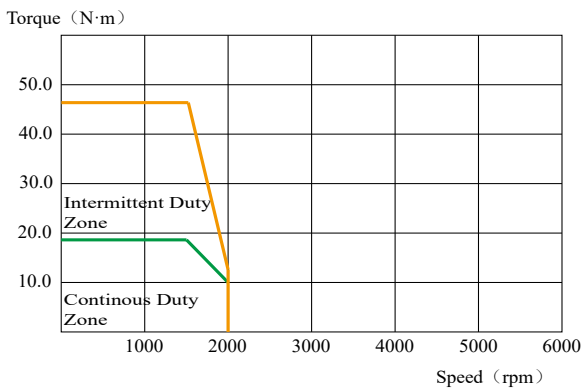

180 bases 4500w2000rpm

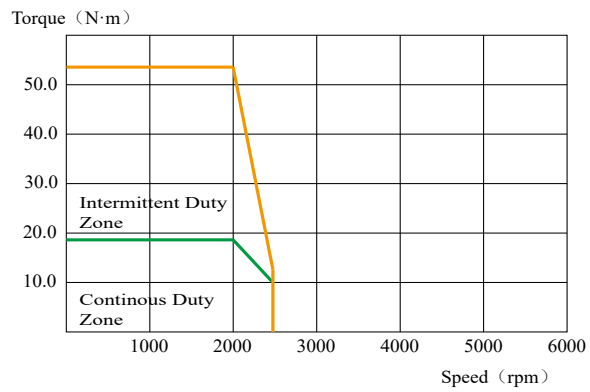

130 base 5500w1500rpm

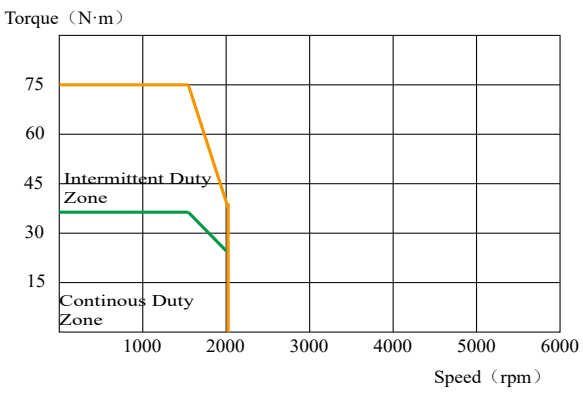

180 base 7500w1500rpm

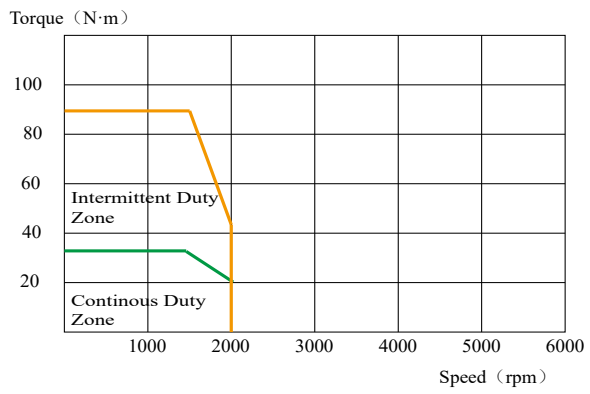

Non-standard motor specifications

90 base series

Motor model	Rated power(kW)	Rated line voltage(V)	Rated line Current(A)	Rated speed(rpm)	Rated torque(N·M)	Max torque(N·M)	Rotor inertia(Kg·M ²)
SY-90KP073A20□□YYB	0.7	220	3.0	2000	3.5	10.5	3.4×10^{-4}
SY-90KP100A25□□YYB	1.0	220	4.0	2500	4.0	12	3.7×10^{-4}

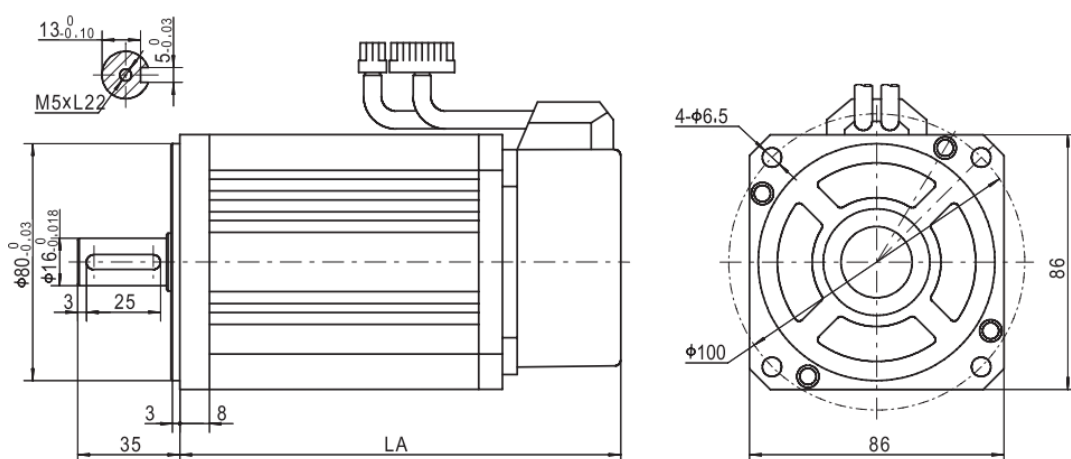

	90 series	
Rated torque(N·M)	3.5	4
Without electronic brake(mm)	172.0	182
With electronic brake(mm)	214.0	224

110 base series

Motor model	Rated power(kW)	Rated line voltage(V)	Rated line Current(A)	Rated speed(rpm)	Rated torque(N·M)	Max torque(N·M)	Rotor inertia(Kg·M ²)
SY-110KP120A30□□YYB	1.2	220	5.0	3000	4.0	12	5.4×10^{-4}
SY-110KP180A30□□YYB	1.8	220	6.0	3000	6.0	18	7.6×10^{-4}

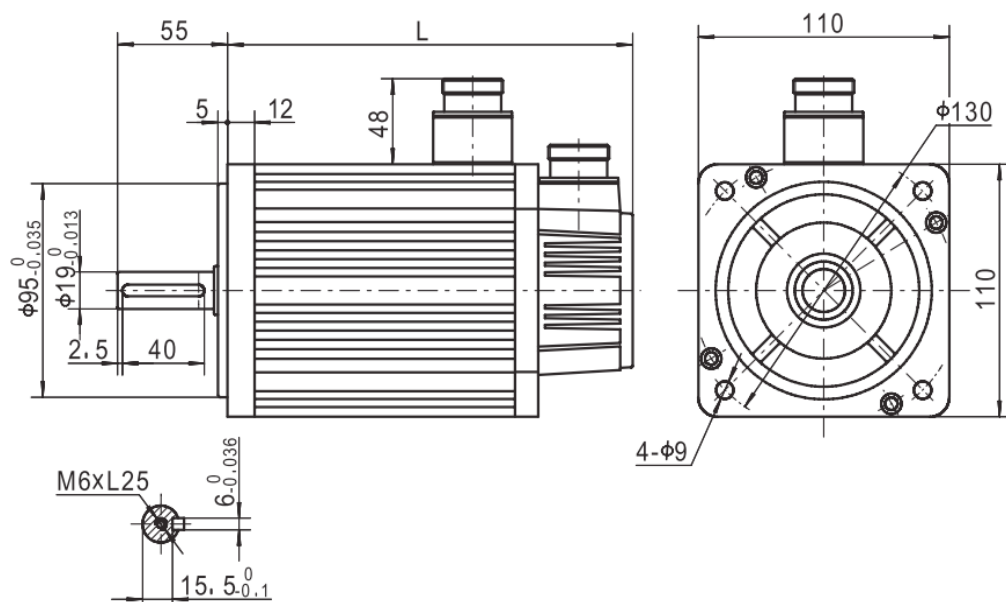

	110 series	
Rated torque(N·M)	4	6
Without electronic brake(mm)	189	219.0
With electronic brake(mm)	254	284.0

Torque characteristic curve

90 base series

90 base 700w2000rpm

Torque (N·m)

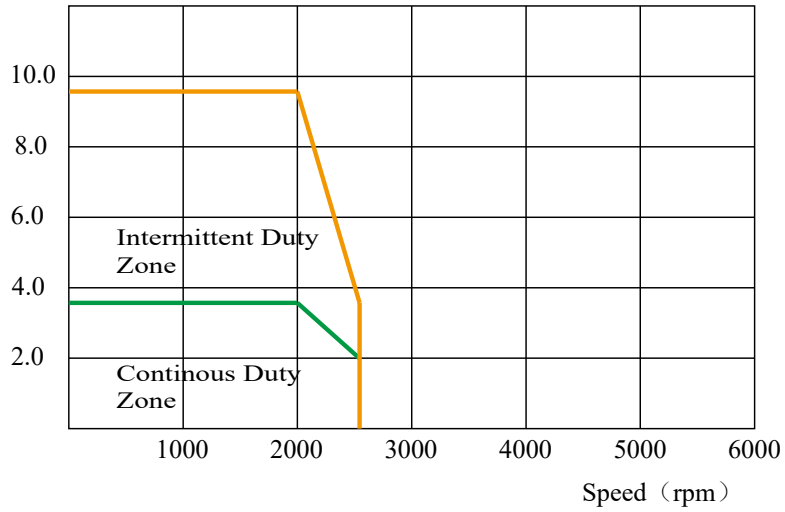

90 base 1000w2500rpm

Torque (N·m)

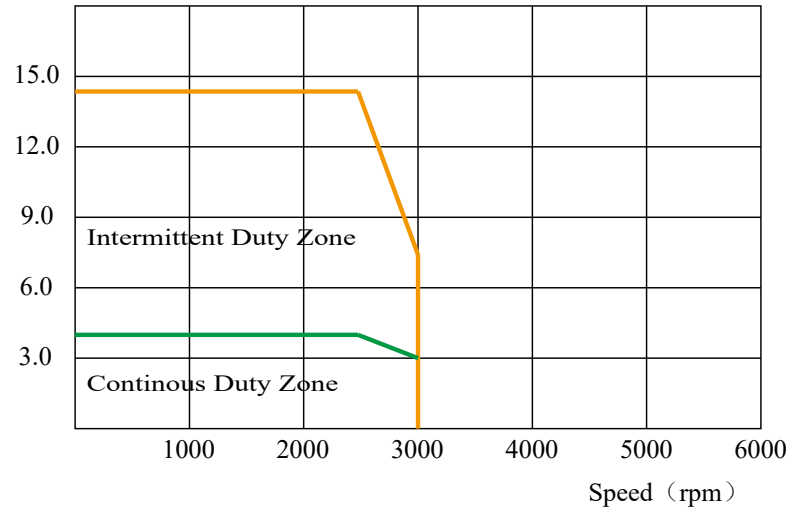

110 base series

110 base 1200w3000rpm

Torque (N·m)

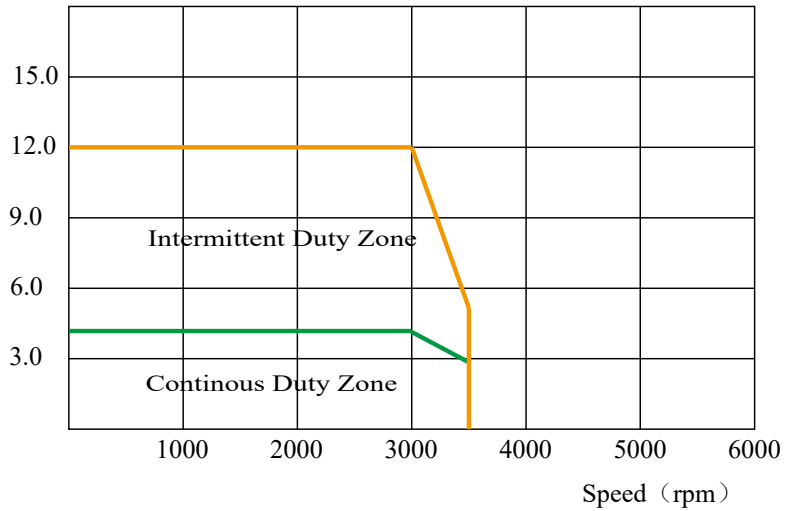

180 base 1800w3000rpm

Torque (N·m)

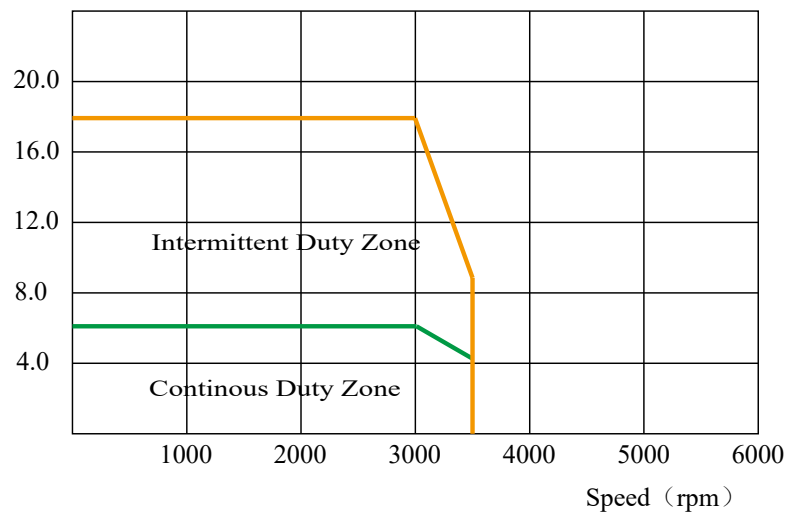

ARCO CONTROL

 :051-37133855-6

 :09014284236

WWW.ARCOKALA.COM

Power cable and encoder cable

Nameplate

Model: SY-DL 040-A -3 (-T)
 ① ② ③ ④ ⑤ ⑥

- ① SANYU drive ②: Power cable
- ③ Motor power: 020:200W;040:400W;075:750W;100:1kW;150:1.5kW;
200:2.0kW;300:3kW;450:4.5kW;550:5.5kW;750:7.5kW
- ④ Connector: A:Plastic connector;H:Aviation connector;
F:Waterproof connector
- ⑤ Length: 3:3M;5:5M;7:7M;10:10M
- ⑥ Flexible towline

Model: SY-BM 040 S-A -3 (-T)
 ① ② ③ ④ ⑤ ⑥ ⑦

- ① SANYU drive ②: Encoder cable
- ③ Motor power: 020:200W;040:400W;075:750W;100:1kW;150:1.5kW;
200:2.0kW;300:3kW;450:4.5kW;550:5.5kW;750:7.5kW
- ④ Encoder model: B:Normal;S:Provincial line;J:17bit/23bit
- ⑤ Connector: A:Plastic connector;H:Aviation connector;
F:Waterproof connector
- ⑥ Length: 3:3M;5:5M;7:7M;10:10M
- ⑦ Flexible towline

Encoder cable definition

Provincial linear encoder

Plastic connector		→	DB15	
No.	Definition		No.	
1	A+		5	
2	B+		4	
3	Z+		3	
4	A-		10	
5	B-		9	
6	Z-		8	
7	5V		13	
8	GND		14	
9	PE		metal shell	

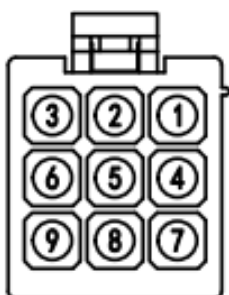

Absolute encoder

Plastic connector		→	DB15	
No.	Definition			Definition
1	E+			
2	E-			
3				
4	SD+		5	
5	SD-		10	
6				
7	5V		13	
8	GND		14	
9	PE		metal shell	



Provincial linear encoder

Aviation connector		→	DB15	
No.	Definition		No.	
1	PE		metal shell	
2	5V		13	
3	GND		14	
4	A+		5	
5	B+		4	
6	Z+		3	
7	A-		10	
8	B-		9	
9	Z-		8	

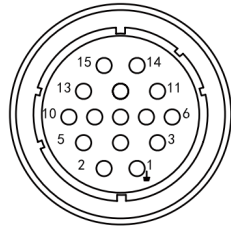

Non-provincial linear encoder

Aviation connector		→	DB15	
No.	Definition		No.	
1	PE		metal shell	
2	5V		13	
3	GND		14	
4	A+		5	
5	B+		4	
6	Z+		3	
7	A-		10	
8	B-		9	
9	Z-		8	
10	U+		2	
11	V+		1	
12	W+		12	
13	U-		7	
14	V-		6	
15	W-		8	

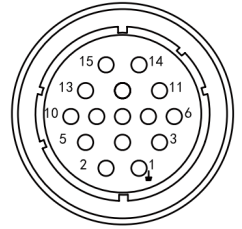

Absolute encoder

Aviation connector		→	DB15	
No.	Definition		No.	
1	PE		metal shell	
2	E-			
3	E+			
4	SD-		10	
5	GND		14	
6	SD+		5	
7	5V		13	

Power cable definition

Plastic connector	
No.	Definition
1	U
2	V
3	W
4	PE



Aviation connector	
No.	Definition
1	PE
2	U
3	V
4	W

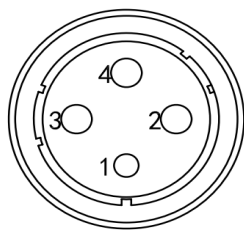

Use caution

■ Use environment

When storing the servo driver without power, store it in a temperature range from -20°C to $+85^{\circ}\text{C}$, and do not generate condensation below 90%RH.

- Overvoltage category: III
- degradation degree: 2
- protection level: 1X
- altitude: less than 1000m

according to the following standards:

- UL508C
- CSA C22.2 No.14
- EN50178
- EN55011 group 1 class A
- EN61000-6-2

■ Installation site

(1) When it is installed in the control cabinet, the size of the control cabinet, the configuration of the servo driver, and the cooling method are designed so that the ambient temperature of the servo driver is below 55°C .

(2) When it is installed near a heating object, in order to keep the temperature around the servo driver below 55°C , please control the temperature rise due to heat radiation and convection to the servo driver due to the heating object.

(3) When it is mounted near a vibration source, please install a vibration-proof device on the mounting surface of the servo driver to prevent vibration from being transmitted to the servo driver.

(4) When it is installed in a place with corrosive gas, please try to prevent the ingress of corrosive gas.

(5) Please do not install it in a humid place, in a place where there is water droplets or cutting oil, in a place where there is a lot of dust or metal dust from the environment, or in a place where there is radiation.

■ Installation direction

As shown in figure a, the installation direction should be perpendicular to the direction of the wall. Use natural convection or cool the servo unit. Please be sure to follow this installation direction. Use 2 to 4 mounting holes (the number of mounting holes depends on the capacity) firmly fix the servo driver to the mounting surface.

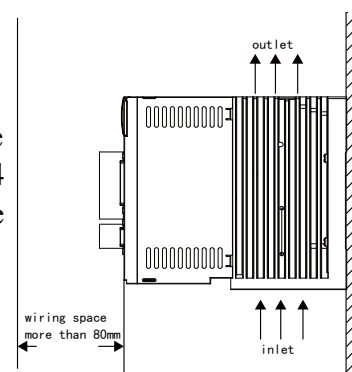

■ Installation standard

Please follow Picture b for install standards in controlling cabinet, and this standard is suitable for install many servo drives in a cabinet.

● Facing direction of servo drive : when install, please make servo drive front face (real install side of panel) to face operator, and make it vertical to the wall.

● Cooling

In order to guarantee cooling by fan and natural convection, please see above picture as reference. And spare enough space around the servo drive.

● When install side by side

Each servo drive need have bigger than 10mm space in left and right side, and bigger than 50mm space for the up and below. Besides, need install cooling fan above the servo drive. We need to average the temperature in the controlling cabinet in order to avoid servo drive environment temperature topical overheat.

● Environmental conditions in the control cabinet

Servo driver ambient temperature: $0\sim 55^{\circ}$

Ctemperature: below 90% RH (relative humidity)

It is should be taken to avoid freezing and frosting. To ensure long-term reliability, it is recommended to use the product at an ambient temperature of less than 45°C .

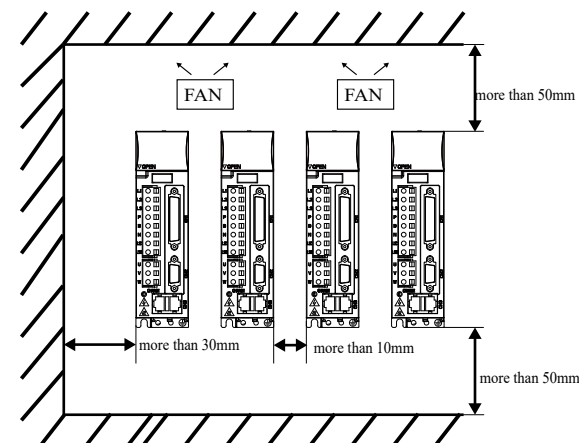

Manufacturer:Shanghai Sanyu Industry Co., Ltd
Add: Unit 723, No. 800 Shangcheng Road, Shanghai, China.
Tel.:+86-21-65046976
Fax:+86-21-51686158
Postal Code:200120
Website:www.sanyuacdrive.com
E-mail:alansunrise@sina.com; sales@sanyuinverter.com