

TemcoLine™

DIGITAL PID CONTROLLER



ARCO CONTROL

T50 SERIES PID Controller User's Manual



:051-37133855-6



:09014284236

WWW.ARCOKALIA.COM



T50

T52/ T53/ T54/ T57/ T59

www.temcoline.com

Thank you for purchasing the T50 series from TemcoLine. The T50 series is a precision industrial controller that uses an advanced 2 degree-of-freedom (DOF) algorithm. The T50 series consists of 5 models, which are T52, T53, T54, T57, and T59. This manual explains the installation, the functions, the operation, and the handling of the products. Please read the manual thoroughly before using the products. If any difficulties arise while using our products, please call our customer service at **+82-1588-5439**.

Pay attention to the followings!

- Use the products under the conditions specified in this manual.
- Please heed the cautions and warnings listed in this manual.
- The contents of the manual may be changed without notice.
- The product is designed to be used installed on a control panel.
- This manual is copyrighted, and may not be copied in part or in whole without permission.
- The manufacturer takes no responsibility for direct or indirect damages caused by careless operation or operation under unpredictable or risky environments.

Safety requirements!

Safety requirements are intended to prevent accidents and dangers through the proper use of the products, so please heed them at all times.

The safety requirements are divided into "cautions" and "warnings", which indicate the following.



WARNING

Serious injury or death may be caused if instructions are not observed.



CAUTION

Failure to observe these instructions may cause damage to the instrument or some injury to the user.



WARNING

1. Use a separate safety device when this product is used to control a device that could harm lives or expensive property in the event of a malfunction or a breakdown. (This may cause fires, deaths, or damage to property.)
2. Do not use this controller at place where there are flammable or explosive gas. (It may cause a fire or explosion.)
3. Before turning the power on, please check that wiring is correct to the number of terminal. (It may cause a fire.)
4. Turn off the power during wiring and maintenance to avoid an electric shock.
5. Do not touch the terminals when it is power on. (It may give an electric shock.)
6. This controller must be mounted on the panel to avoid an electric shock.
7. Do not attempt to disassemble, modify and repair.



CAUTION

1. Please conduct an inspection when water has entered the product. (It may cause short circuits, fires, and malfunction.)
2. This controller should be used indoors. (It may shorten the controller's life or give an electric shock.)
3. Observe the rated voltage and specification. (It may cause a fire or shorten the controller's life.)
4. Be careful that any of foreign materials do not inflow into the controller. (It may cause a fire or malfunction of the controller.)
5. Do not give direct vibration or shock to the controller. (It may cause of malfunction of the controller.)
6. Do not use chemical detergent or solvent, but use a dry towel in cleaning the controller. (It may cause an electric shock or a fire.)
7. Please check the polarity of power before wiring and connecting the sensor. (It may cause an electric shock or explosion.)

Contents

1. Ordering Information	5
2. Input ranges & Output constitutions	7
3. Dimensions & Panel cutouts	9
4. Terminal Arrangements & Wirings	12
5. Ratings & Specifications	14
6. Features & Function	15
7. Check points before Using	16
8. Initial installation & Min. operation procedures	17
9. Entering into "set menu" and Setting method	18
10. Flow Chart (Parameter structure)	20
11. Easy function & Safety function	21
12. Functions of each setting group	23
1) Control group setting	23
2) Set value(SV) group setting	24
3) Auto tuning(AT) group setting	25
4) P.I.D group setting	25
5) Heater break alarm(HBA) group setting	27
6) Alarm(ALARM1,2) group setting	27
7) Retransmission group setting	29
8) Communication group setting	30
9) Output group setting	34
10) Input group setting	36
11) Error indication during operation	37

1. Ordering Information

1) **T 5** - □ □ □

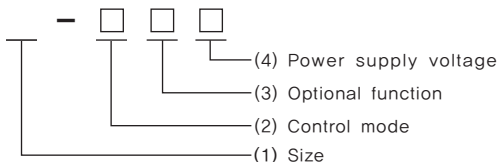

(1) Size

Code	Model	Size	Remarks
2	T52-SERIES	48(W) x 96(H) x 77(D)	Option: 0, 1, 2
3	T53-SERIES	96(W) x 48(H) x 77(D)	Option: 0, 1, 2
4	T54-SERIES	48(W) x 48(H) x 99(D)	Option: 0, 1, 2, 3, 4, 5, 6, 7
7	T57-SERIES	72(W) x 72(H) x 77(D)	Option: 0, 1, 2
9	T59-SERIES	96(W) x 96(H) x 77(D)	Option: 0, 1

(2) Control mode

Code	Description	Remarks
S	SINGLE: Standard	Heating or Cooling control
D	DUAL: Heating & Cooling	Heating and Cooling control



ARCO CONTROL

☎ **:051-37133855-6**

💬 **:09014284236**

WWW.ARKOKAIA.COM

(3) Optional function

Model	Code	Description	Remarks
T52, 53-SERIES	Basic function	RELAY output 1, Alarm output 2, SCR(4~20mA), SSR(Voltage pulse) 1, RET(4~20mA Retransmission output)	Basic function + (Option code)
	0	D,I (SV2, 3) External digital input	Ex.) T52, T53-S00
	1	Communication (RS-485, Modbus)	Ex.) T52, T53-S10
	2	HBA(CT) Heater break alarm	Ex.) T52, T53-S20
T54-SERIES	Basic function 0	RELAY output 1 (ALARM or MAIN), SCR(4~20mA), SSR(Voltage pulse) 1	Basic function + Option code (0 : No option)
	1	RET(4~20mA Retransmission), Alarm output 2	Ex.) T54-S10
	2	HBA(Heater break alarm), Alarm output 2	Ex.) T54-S20
	3	D,I(SV2, 3) External input, Alarm output 2	Ex.) T54-S30
	4	RET(4~20mA Retransmission), Communication (RS-485, Modbus)	Ex.) T54-S40
	5	HBA(CT) Heater break alarm, Communication (RS-485, Modbus)	Ex.) T54-S50
	6	D,I(SV2, 3) External input, Communication (RS-485, Modbus)	Ex.) T54-S60
	7	Communication (RS-485, Modbus), Alarm output 2	Ex.) T54-S70
T57-SERIES	Basic function 0	RELAY output 1, Alarm output 2, SCR(4~20mA), SSR(Voltage pulse) 1	Basic function + Option code (0 : No option)
	1	Communication (RS-485, Modbus), RET(4~20mA Retransmission), HBA(CT) Heater break alarm	Ex.) T57-S10
	2	D,I(SV2, 3), RET(4~20mA Retransmission), HBA(CT) Heater break alarm	Ex.) T57-S20
T59-SERIES	Basic function 0	RELAY output 1, Alarm output 2, SCR(4~20mA), SSR(Voltage pulse) 1, RET(4~20mA Retransmission)	Basic function + Option code (0 : No option)
	1	Communication (RS-485, Modbus), HBA(CT) Heater break alarm	Ex.) T59-S10

(4) Power supply voltage

Code	Description	Remarks
0	100 ~ 240V AC	General-purpose usage
1	24V AC or DC	Alternating or Direct current usage

2) Example of model building

Ex.) T54-S10

- | | | |
|---|-------|--|
| (1) Size : 48(W) x 48(H) x 99(D) | ⇒ "4" |  T54-S10 |
| (2) Control mode : SINGLE | ⇒ "S" | |
| (3) Optional function : RET, Alarm output 2 | ⇒ "1" | |
| (4) Supply voltage : 100~240V AC | ⇒ "0" | |

2. Input ranges and Output constitutions

1) Input ranges

※ The T50 series has multiple inputs, which may be set and changed by the user.

Input type	Input	Setting Code	Temperature range	Accuracy	Remarks
Thermocouple (T.C)	K	1	-200 ~ 1370	±0,3% of F.S + 1 Digit	* F.S is max. value to min. value of each range. * Digit is minimum of display.
		2	-199,9 ~ 999,9		
	J	15	-200 ~ 1000		
		3	-199,9 ~ 999,9		
	E	16	-200 ~ 1000		
		4	-199,9 ~ 999,9		
	T	5	-199,9 ~ 400,0		
	R	6	0 ~ 1700		
	B	7	400 ~ 1800		
	S	8	0 ~ 1700		
	L	17	-200 ~ 900		
		9	-199,9 ~ 900,0		
	N	10	-200 ~ 1300		
	U	11	-199,9 ~ 400,0		
C (W5)	12	0 ~ 2300			
D (W3)	13	0 ~ 2400			
RTD	JPt100Ω (JIS, KS)	20	-199,9 ~ 500,0		
		22	-200 ~ 500		
	Pt100Ω (DIN, IEC)	21	-199,9 ~ 640,0		
		23	-200 ~ 640		
Voltage (V DC/mV DC)	0~100 mV DC	33	0 ~ 100 mV DC	※ When using 1~5V input (30), the interior jumper switch must be relocated.	
	-10~20 mV DC	32	-10 ~ 20 mV DC		
	1~5 V DC	30	1~5 V DC		
Current	4~20 mA DC	30	When using current input, use the resistor 250 Ω on input terminal.		

※ How to change the interior switch when using 1~5V input

-
- ① Remove plate or take out the main cover.
 - ② Move and insert the jumper that pulled by tweezers.
 - ③ Relocated jumper as above and attach plate or mounted cover.

2) Output constitutions

The T50 series has multiple outputs.

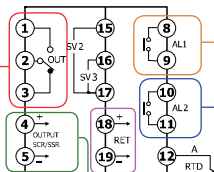
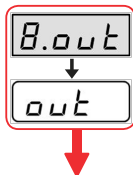

※ The figure on the left uses the terminal socket of T57-S20 as an example to illustrate the output response relationship.

General type	Setting number	OUTPUT-1			OUTPUT-1 (ALARM 1,2)		
		Relay output	SSR/SCR OUTPUT		AL1 output	AL2 output	SCR output
			SSR output	SCR output			
T50-SXX	0	OUT(ON/OFF)	ALM1(54-S0x)	-	ALARM1	ALARM2	RET
	1	ALM1(54-S0x)	OUT(PID)	-			RET
	2	ALM1(54-S0x)	-	OUT(PID)			RET
	3	OUT(PID)	ALM1(54-S0x)	-			RET

(1) Summary and explanation of output settings

- **Relay output of ON/OFF control [Output setting number : 0]**
This is a simple on/off control, mainly used to control cooling devices.
- **SSR output of PID control (Voltage pulse) [Output setting number : 1]**
This is the most widely used setting, and the default value at the point of manufacture.
- **SCR output of PID control (4~20mA current output) [Output setting number : 2]**
This setting is used mainly with thyristor power regulator (TPR) modules, and is capable of precision control.
- **Relay output of PID control [Output setting number : 3]**
This is the most cost-efficient method of implementing PID control and is used mainly with magnetic switches (electric switches). However, it may wear the contact point, and is difficult to use in places that require fast response.

(2) Alarm output of T54(48x48) basic type(S00)

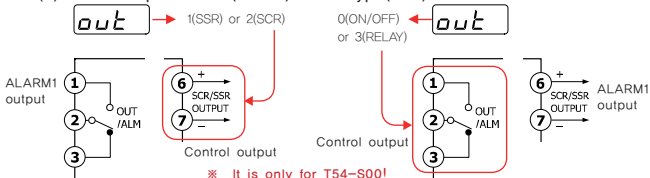

With the basic model of T54 (48x48), caution is required when using it alarm output. When control output is being used as a relay, the alarm output will be SSR output (voltage pulse). In this case, use SSR or alarm option (S10, S20, S30) enabled models.

3. Dimensions and Panel cutouts

1) T52 (48x96 mm) Dimensions

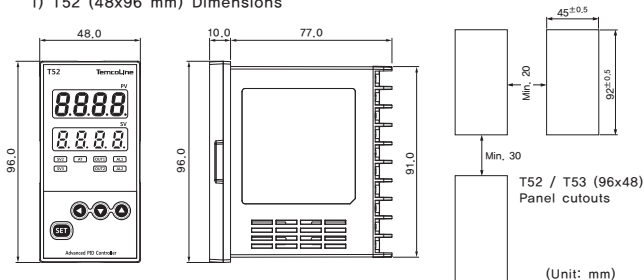

2) T53 (96x48 mm) Dimensions

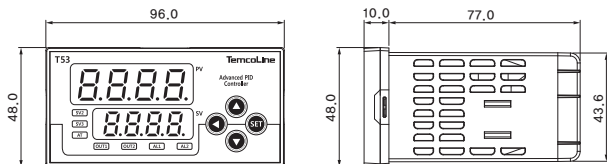

3) T54 (48x48 mm) Dimensions

T54 (48x48) Panel cutouts

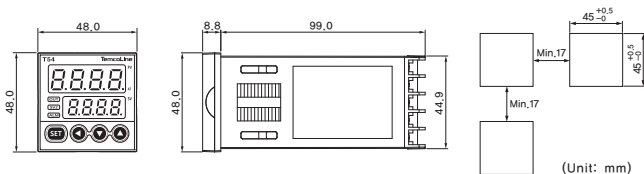

4) T57 (72x72 mm) Dimensions

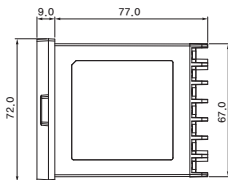
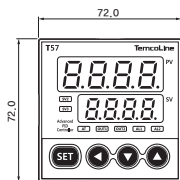

T57 (72x72) Panel cutouts

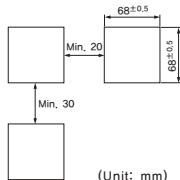

(Unit: mm)

5) T59 (96x96 mm) Dimensions

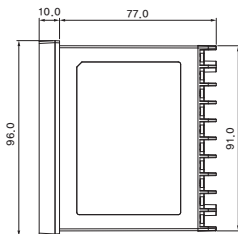
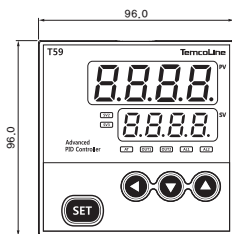

T59 (96x96) Panel cutouts

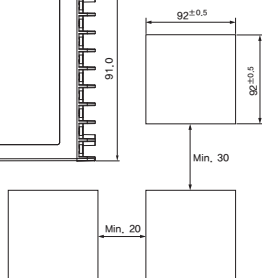

(Unit: mm)

※ HBA option (Heater break alarm)

Current transformer (CT) : using 800:1 CT of TC8L or CTL-6-S

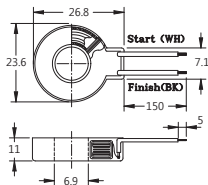

TC8L (Temcoline)

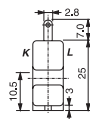
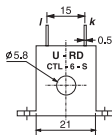

CTL-6-S (U-RD)

Panel cutouts

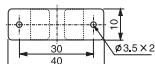

(Unit: mm)

6) Installation

(1) T54-SERIES

- ① Bore a hole in the panel, referring to the panel cutouts on the previous page.
- ② Insert this device into the front of the panel.
- ③ From the rear of controller, slide the bracket over the housing.
- ④ Push the bracket in until the device has been fixed securely onto the panel.
- ⑤ Secure using screws on the two locations at top and bottom as shown on Figure 2.

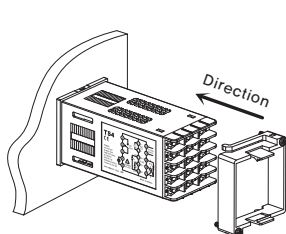

[figure 1]

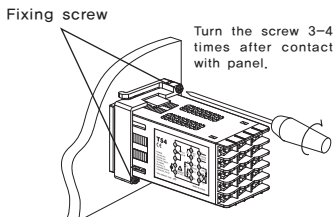

[figure 2]

(2) T52/ T53/ T57/ T59-SERIES

- ① Bore a hole in the panel, referring to the panel cutouts on the previous page.
- ② Insert this device into the front of the panel.
- ③ Insert 2 brackets, one each on the bracket holes on the top and the bottom of the device.
- ④ Secure using screws on the two locations at top and bottom.

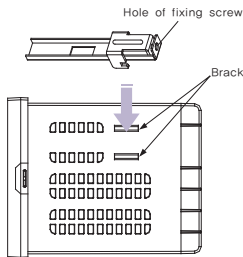

[figure 1] Top side

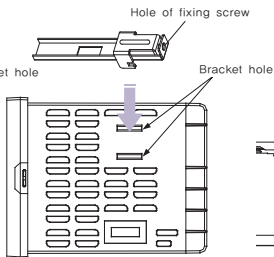

[figure 2] Bottom side

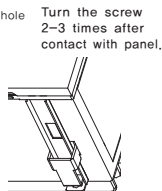

[figure 3] Fixing completion

4. Terminal Arrangements and Wirings

1) T52 (48x96 mm), T53 (96x48 mm)

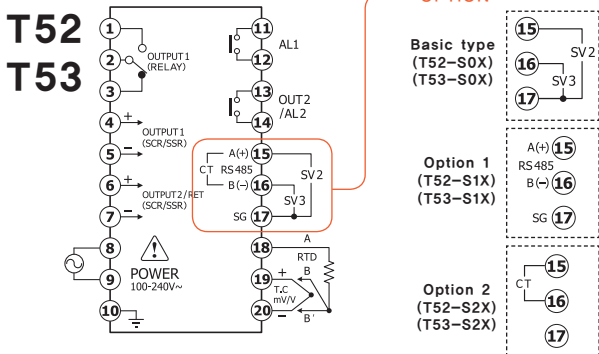

2) T54 (48x48 mm)

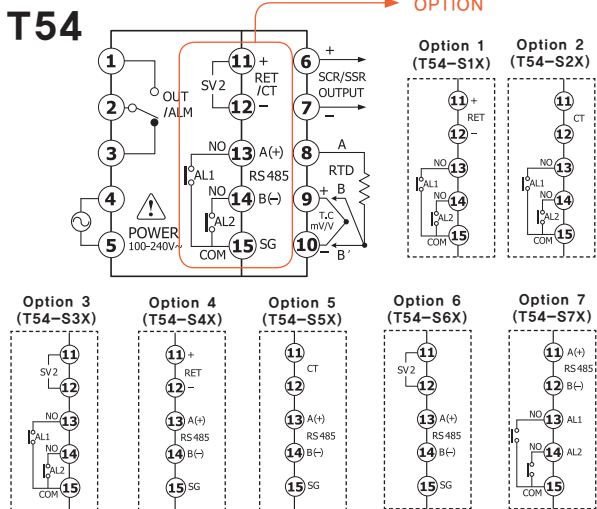

3) T57 (72x72 mm)

T57

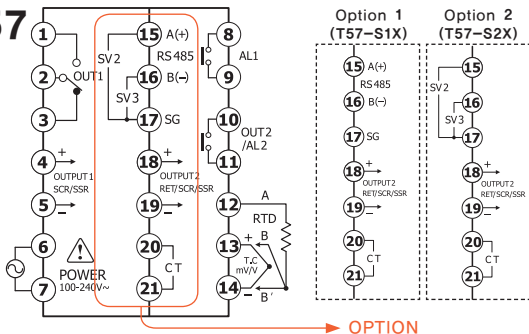

4) T59 (96x96 mm)

T59

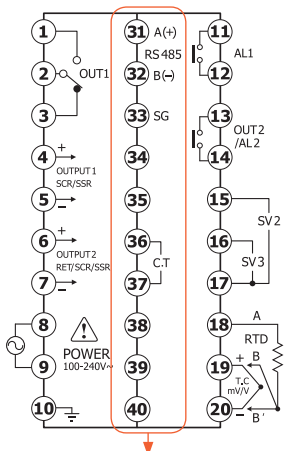

OPTION 1 (T59-S1X)

※ Terminal explanation (T59-S10 basis)

- Terminal ① ② ③ : OUT1 only for output selection no. 0, 3 (Relay output) mode.
- Terminal ④ ⑤ : OUT1 only for output selection no. 1, 2 (SSR, SCR output) mode
- Terminal ⑥ ⑦ : RET(Retransmission 4~20mA) or for power of sensor SPS. (DC 15V)
- Terminal ⑧ ⑨ : Power supply terminal.
- Terminal ⑪ ⑫ : Alarm1 output terminal.
- Terminal ⑬ ⑭ : Alarm2 output terminal.
- Terminal ⑮ ⑯ ⑰ : The external D,I input terminal may be used when (DIS=ON), and the target value may be controlled. (SV1, SV2, SV3)
- Terminal ⑱ ⑲ ⑳ : Input terminals.
- Terminal ㉑ ㉒ ㉓ : RS-485 communication terminals completely isolated, Modbus-ASCII, Modbus-RTU, PC-Link, TL-Link basic.
- Terminal ㉔ ㉕ : C,T(800:1) input terminals for Heater break alarm.

5. Ratings and Specifications

Model		T50–SERIES
Power Supply		Rating 100~240V AC 50~60Hz (voltage operating range: 85~265V AC) ※ Option: Rating 24V AC or DC (operating voltage range 20~28V DC)
Power Consumption		5VA (Max.)
Input Type		TC: K, J, T, E, R, B, S, L, N, U, C(W5), D(W3) Platinum RTD: KPt100(KS), JPt100(JIS), Pt100(DIN) Current input(A): 4~20mA DC Voltage input(V): 1~5V DC, -10~20mV DC, 0~100mV DC
Display Accuracy		±0.3% of FS +1 Digit
Input Impedance		Current input(250Ω), Voltage input(including TC) 1MΩ min, (RTD line resistance: ≤ 10Ω, when 3–line resistance are the same)
Input Sampling Period		50~250ms (variable according to SG–PID algorithm)
Control Output	Relay	1c 250V AC, 3A(resistance load) electric lifespan ≥ 100,000 min. (time proportional PID output or ON/OFF output)
	Voltage (S.S.R)	DC15V 25mA (Built-in short protection circuit) Voltage pulse (time proportional PID output)
	Current (S.C.R)	4~20mA DC, load impedance ≤ 600Ω (continuous PID output)
Control Method		Super 2 degree-of-freedom PID (SG–PID algorithm), S–Fuzzy, Auto–Tuning
Multi SV Input(D.I)		ON: ≤ 1KΩ, OFF: ≥ 100KΩ (external control SV1, 2, 3)
Retransmission Output		4~20mA DC, load impedance ≤ 600Ω resolution 1/4,600 PV(process value), SV(set value), MV(manipulated variable [%]), SPS(sensor module power supply)
Alarm Output	ALARM 1, 2 HBA common (C,T)	1a 250V AC 3A (Resistive load) HBA : 1~50A AC (Resolution 0.5A)
Communication Output		2 wires RS485 totally independent isolation structure Max. speed : 9,600bps/ Max. connect no. 99 devices (32 devices recommended) Support protocol : PC–Link, TL–Link, Modbus–ASCII, Modbus–RTU
Ambient Temperature and Humidity		-10~50°C/ relative humidity 25~85% RH (but with neither condensation nor freezing)
Weight (Bracket, Accessories included)		•T52, T53, T57: 230g •T54: 140g •T59: 320g ※ + 30g, if options are added

6. Features and Function (ex. T54–SERIES)

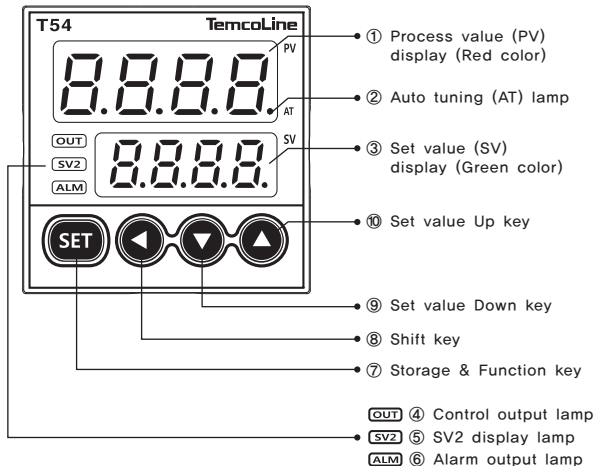

※ Description

Name	Function
① Process value	Display the process value. (red color)
② Auto tuning lamp	Flash every 0,5 second during auto tuning.
③ Set value display	Display the set value, codes, and modes.
④ Control output lamp	Lights when the control output is ON.
⑤ SV2 display lamp	Lights when the SV2 is displayed.
⑥ Alarm output lamp	Lights during the alarm is ON.
⑦ SET Function key	Use to move the menus, to store, and to operate.
⑧ ◀ Shift key	Use to shift the digits.
⑨ ▼ Set value down key	Use to decrease set value and to move the menu.
⑩ ▲ Set value up key	Use to increase set value and to move the menu.

7. Check points before Using

1) Default values at the point of manufacture

The default input and output values of the product at the point of manufacture are as follows.

Input : K-Type (Code No. 1) Output : SSR (Code No. 1)

※ In the case of the basic model of T54-S00 only, when SSR(1) or SCR(2) is chosen as the output mode, Alarm 1 output will be in main relay. (Refer to page 8 for details.)

2) 7 Segment display indications

A	b	c	d	E	F	G	H	I	J	K	L	ñ
A	B	C	D	E	F	G	H	I	J	K	L	M
n	o	P	q	r	4	t	u	y	y	v	y	z
N	O	P	Q	R	S	T	U	V	W	X	Y	Z

3) Initial display on power supply (T54 SERIES basis)

Model Name

Option indication

- 0 : Basic type (No option)
- 1 : RET, ALARM1, 2
- 2 : HBA(CT), ALARM1, 2
- 3 : DI(SV1, 2), ALARM1, 2
- 4 : RET, RS-485
- 5 : HBA(CT), RS-485
- 6 : DI(SV1, 2), RS-485
- 7 : RS-485, ALARM1, 2

Output type indication

- 0 : RELAY ON/OFF control
- 1 : SSR (VOLT-PULSE) PID control
- 2 : SCR (4~20mA) PID control
- 3 : RELAY PID control

Input type indication

- 01 : K-Type (-200~1370 °C)
- 02 : K-Type (-199.9~999.9 °C)
- ⋮
- 33 : mV DC (0~100mV)

Firmware version display

8. Initial installation and Minimum operation procedures

The following are the instructions for initial installation and minimum operation procedures. Please read the contents of this manual, including the general functions outlined here, as thoroughly as possible before operating the device.

1) Check the external wiring diagram and specifications.
(power supply and terminal arrangement)

2) Check input and output specifications!

The default setting for the T50 series at the point of manufacturer are as follows.

Input : K(CA) Type (setting code 1)

Output : SSR mode (setting code 1)

If you wish to change the input or the output type, please select the option you desire on the input group and the output group menus.

※ The input type settings must be configured first before changes to other set values are made.

When the input type is changed, all other parameters (set values) are reverted to their factory default.

3) Select the desired set value (SV).

4) Please set auto-tuning or P, I, D values to suit the operating environment. Auto-tuning is recommended except under special circumstances.

※ To ensure safety and prevent wrong operation, once auto-tuning has been completed, "level-2"(setting menu display limit) will be set automatically.

At the same time, setting menu output group(8.out) and input group (9.in) are not displayed.

If needed reset, please change to "level-3"(setting menu display limit) and operate

Please refer to the "3) setting menu display limit" at page 22.

9. Entering into "set menu" and Setting method

1) Input & Output type setting

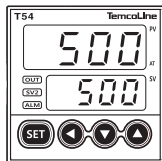

Temcoline products are universalized input and output. Please set up input and output type firstly and use when install our unit.

SET more than 3 sec.

dc4P

When it is LEVEL 3, input/output set is available.
(Refer to p22, 3) Setting menu display limit (LEVEL) function)

SET Press once shortly

0.ct.r

Press once shortly

9.L.n

SET

① Input type setting : Select the desired input sensor type, (setting code 1~33 / refer to P7, input ranges)

! []

un.t

SET

b.out

Press once shortly

B.out

SET Press once shortly

out

② Output type setting : Select the desired output type, (setting code 0~3 / refer to P8, Output Configuration)

! []

a.P.c.t

SET

oL-L

INPUT(T,C)	CODE	TEMP. RANGE	INPUT(RTD)	CODE	TEMP. RANGE
K	1	-200 ~ 1370	JP1100Ω (JIS, KS)	20	-199,9 ~ 500,0
	2	-199,9 ~ 999,9		22	-200 ~ 500
	15	-200 ~ 1000	PI100Ω (DIN, IEC)	21	-199,9 ~ 640,0
3	-199,9 ~ 999,9	23		-200 ~ 640	
E	16	-200 ~ 1000			
	4	-199,9 ~ 999,9			
T	5	-199,9 ~ 400,0			
R	6	0 ~ 1700	INPUT(V DC/mV DC)		CODE
B	7	400 ~ 1800	0~100 mV DC		33
S	8	0 ~ 1700	-10~20 mV DC		32
L	17	-200 ~ 900	1~5 V DC		30
	9	-199,9 ~ 900,0	4~20mA DC (Use 250Ω resistor)		
N	10	-200 ~ 1300			
U	11	-199,9 ~ 400,0			
C (W5)	12	0 ~ 2300			
D (W3)	13	0 ~ 2400			

SETTING CODE	CONTROL OUTPUT
0	RELAY ON/OFF CONTROL
1	SSR P,I,D CONTROL
2	SCR (4~20mA) P,I,D CONTROL
3	RELAY P,I,D CONTROL

2) Set value(SV) setting [in condition of Mvn = OFF (basic)]

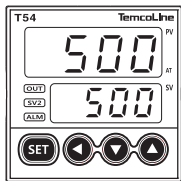

- ① Enter to setting mode by **SET** key
- ② Set a desired value by **◀ ▼ ▶** key
- ③ Store a value by **SET** key

3) Quick auto tuning

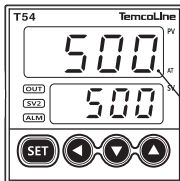

AT operation start : **SET** + **▲** 0,5 second

AT stop by performce : **SET** + **▲** 0,5 second

→ AT command lamp (flash every 0,5 sec.)

Auto-tuning is required before operating for the first time, Set the target value(SV) in the range mainly used and run auto-tuning. When auto-tuning begins, the "auto-tuning command lamp" will flash every 0,5 second and will turn off upon completion of the auto-tuning process, Please refrain from operating the keys while auto-tuning is in progress.



☎ :051-37133855-6

☎ :09014284236

WWW.ARCOKALIA.COM

10. Flow Chart (Parameter structure)

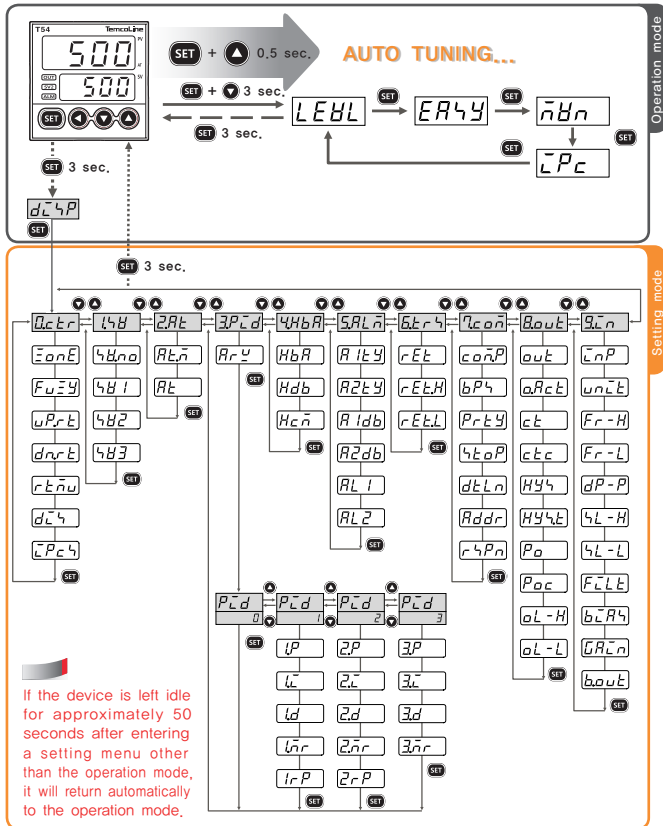

The full menu diagram above shows all control and setting menus on the T50 series, but during actual operations the menus that are the most relevant to the situation according to the options and the operation mode, providing a simpler user interface while retaining functionality.

11. Easy function and Safety function

1) Easy Menu

"Easy Menu" is displays the most frequently used functions of the T50 series, and hides the others.

(Setting method)

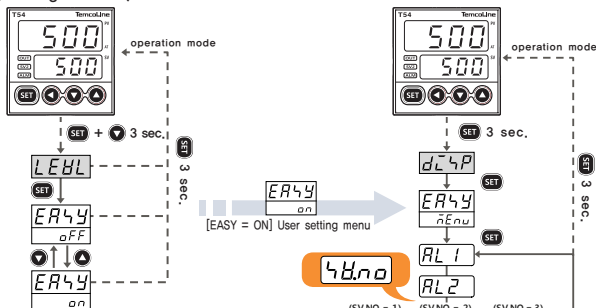

2) Control output[%] (Mvn) check and manual operation mode

"Mvn [%] check function" display the control output[%], which can be viewed by pressing the **SET** key while operating in normal operation mode and is shown as a percentage of control output (0~100(%)) in the SV display. In this normal operation mode, by pressing the **SET** key each, showing the SV and Mvn values alternately. Any required, value of SV can be adjusted by **DOWN**, **UP** or **LEFT** key and stored by pressing **SET** key.

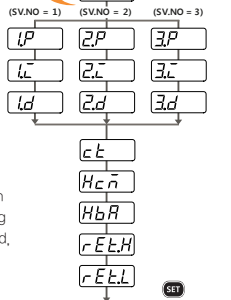

(Setting method)

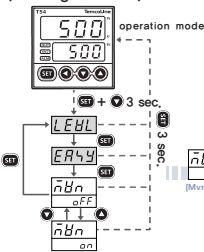

(In condition of Mvn=ON)

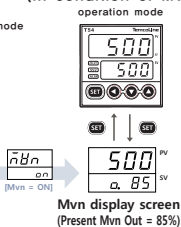

(Manual operation for Mvn)

You can press/hold **UP** **DOWN** key at the same time more than 2 seconds for control output test at the Mvn mode.

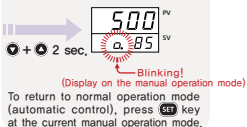

3) Setting menu display limit (LEVEL) function

The setting menu display limit function limits the range displayed according to the level set in the control and the setting menus in the T50 series. This can be used, for example, to prevent user's miscontrol after all settings have been configured.

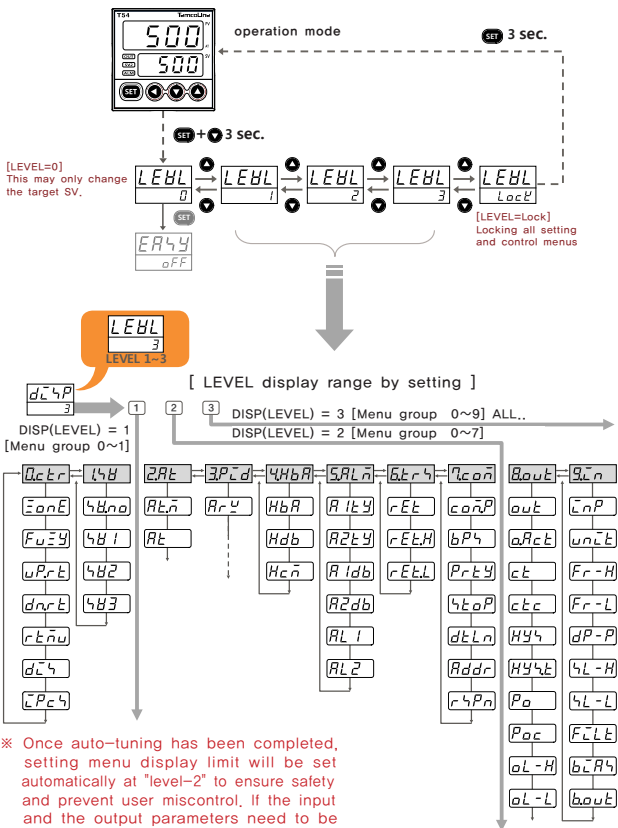

※ Once auto-tuning has been completed, setting menu display limit will be set automatically at "level-2" to ensure safety and prevent user miscontrol. If the input and the output parameters need to be changed after auto-tuning, set to "level-3" before doing so.

12. Functions of each setting group

1) Control group setting

Control zone, fuzzy function, and ramp function may be selected, and the fuzzy function works only in PID control mode. In addition, as shown in Table 1, the 3 set values (SV1, SV2, SV3) preset by the two external contact inputs may be selected and controlled.

Display	Description	Setting range	Condition	Initial Value
	Enter to control group	-	-	-
	Control zone selection	OFF / ON	Always	OFF
	Fuzzy function selection	OFF / ON	PID control	OFF
	Initial rising temp. setting (Ramp function)	OFF / EUS (0 ~ 100 %)	Always	OFF
	Initial drop temp. setting (Ramp function)	OFF / EUS (0 ~ 100 %)	Always	OFF
	Time (Hour/Minute) unit selection (Ramp function)	HOUR / MIN	Always	HOUR
	External contact input ON/OFF switch	OFF / ON	D I option	OFF

※ EU : An engineering unit in compliance with the input range

Ex.) Input selection no. : 01 (K-TYPE)

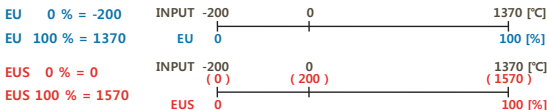

(1) **Direct input switch (DIS):** This function selects whether to use direct input switch.

※ Please use a non-voltage contact (relays, switches) for direct input. If a non-contact device such as a semiconductor are used, please operate within the ranges

ON = under 1KΩ
 OFF = over 100KΩ

Target set value on External contact input (DIS=ON)

DIS selection	SV selection made by external contact signal		
OFF	NO external contact signal		
ON	external signal	SV2	SV3
	display selection	display the SV1	OFF OFF
	display the SV2	ON OFF	
display the SV3	ON ON		

(2) **Control zone (ZONE):** In an environment with large temperature fluctuations, the optimal PID value may vary according to the temperature range. This function allows 3 separate temperature ranges to be set in order to control the PID value in each of them.

- (3) **Fuzzy** : The T54 series is equipped by default with an S–PID unique to Temcoline, and separate fuzzy or ARW functions are usually not required, so this can be kept off most of the time. Use under special circumstances or when external disruptions cause repeated overshooting.
- (4) **Ramp function** : This controls the incline toward the initial set values (SV1, SV2, SV3). To use this function, set the time at the initial temperature increase and decrease settings, or define the desired initial temperature increase or decrease per hour or minute. Once this has been set, a steady incline from the starting temperature to the set values will be maintained.

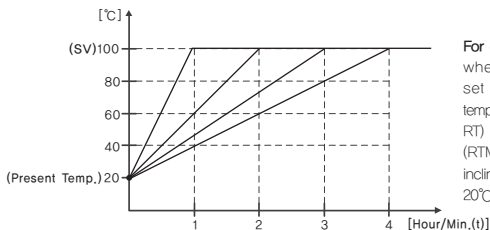

For example,
when the desired SV is set as 100°C, the initial temperature increase as (UP, RT) 20°C, and the time unit (RTMU) as in minutes, the incline to the SV will be at 20°C per minute.

2) Set value(SV) group setting

With the SV group, the 3 control set values (SV1, SV2, SV3) must be set before they can be selected and controlled as desired by direct input signal or by the internal menu.

- ※ In the case that direct input signal is used to control, the direct input switch (DIS) must be on. If the switch is off, the selection will be made by the set value number (SV no).

Display	Description	Setting range	Condition	Initial Value
1.58	Enter to set value setting group	-	-	-
48.no	Set value number selection	1 / 2 / 3	Always	1
481	Set value 1 (SV1) setting	EU (0.0 ~ 100.0 %)		EU (0.0%)
482	Set value 2 (SV2) setting	EU (0.0 ~ 100.0 %)		EU (0.0%)
483	Set value 3 (SV3) setting	EU (0.0 ~ 100.0 %)		EU (0.0%)

3) Auto tuning(AT) group setting

Before the PID temperature controller can be used for the first time, the P, I, D values must be tuned. The auto-tuning function finds the optimal value by tuning automatically according to the load factor and other conditions.

Please make sure that the controller is tuned before using it for the first time, by defining the set values in the most frequently used range and running auto-tuning. When auto-tuning begins, the "auto-tuning command lamp" will flash every 0.5 second and will turn off upon completion of the tuning process.

Please refrain from operating the keys while auto-tuning is in progress.

The T50 series is able to perform several kinds of auto-tuning.

To make auto-tuning easier, the Quick-AT function, which allows the command to be executed with a simple external key combination.

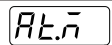
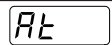
Display	Description	Setting range	Condition	Initial Value
	Enter to auto tuning setting group	-	PID control	-
	Auto tuning (AT) type selection	Standard / Low	PID control	STD
	Auto tuning (AT) start selection	OFF / 1 / 2 / 3 / Auto	PID control	OFF

 This product performs optimally when auto-tuning is executed in the STD mode according to the S-PID algorithm. We recommend that you operate the product in the STD mode.

(1) **Types of auto-tuning (AT)** : The T50 temperature controller has two tuning methods, standard auto-tuning (STD: based on the set value) and low-SV tuning (LOW: SV - 10%). Under normal conditions, the standard auto-tuning is recommended.

(2) **Start auto-tuning** : This menu starts the auto-tuning process. Select the number of the SV that you wish to tune (SV1 → " 1 ", SV2 → " 2 ", SV3 → " 3 "), and auto-tuning will begin, making automatic calculations which will be stored under the P, I, D values of the corresponding SV.

When set on AUTO, SV1~3 will be auto-tuned consecutively if in the control group ZONE is set as off. If ZONE is on, groups 1, 2, and 3 will be created based on the ranges set in 1RP and 2RP of the PID group, and the results will each be stored under the PID groups 1, 2, and 3.

4) P.I.D group setting

This is used to view the PID and ARW values produced by auto-tuning in the auto-tuning groups, and to change the values manually.

(1) In the PID selection group, press the **SET** key to set automatically or manually the anti-reset wind-up ARW value. Pressing again the **SET** key will display the PID selection mode, where you may choose to view the group PID parameters by selecting 0~3. For example, when " 0 " is selected in the PID mode, no PID values will be shown. Use the **▲** key to select " 1 " and then press the **SET** key to view the PID values for group 1. Selecting " 2 " and " 3 " will display the values for groups 2 and 3 respectively. (This is intended to prevent accidentally mishandling the settings.)

- (2) Manual reset (MR) is displayed when the integral value set at OFF, and it is used to manually remove control offsets.
- (3) When the control group zone selection mode is on, 2 zone location settings may be made to control 3 zones.
- (4) The " n " in the table as below indicates that the number may be from 1 to 3.

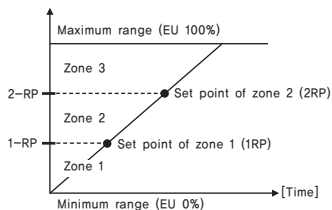

This product provides optimal control when ARW is in automatic mode according to the S-PID algorithm. We recommend that you used the product in the automatic mode. The ARW function is actually seldom required with S-PID.

Display	Description	Setting range	Condition	Initial Value
3P \bar{L} d	Enter to P,I,D setting group	-	PID control	-
Ar \bar{U}	Anti Reset Wind-up setting	Auto / 50,0 ~ 200,0 %	PID control	AUTO
P \bar{L} d	P,I,D group selection	0 / 1 ~ 3	Always	0
n.P	n, Proportional (P)	0,1 (D-TYPE : 0,0) ~ 999,9 %	PID group selection	3,0 %
n. \bar{L}	n, Integral time (I)	OFF / 1 ~ 6000 초	Always	240 SEC.
n.d	n, Differential time (D)	OFF / 1 ~ 6000 초	Always	60 SEC.
n. \bar{r}	n, Manual reset (M,R)	-5,0 ~ 105,0 %	Integral time OFF	50,0 %
n.Pc	n, Proportional band of cooling side (P)	0,0 (ON/OFF 제어시) 0,1 ~ 999,9 %	Heating and Cooling type	3,0 %
n. \bar{L} c	n, Integral time of cooling side (I)	OFF / 1 ~ 6000 초	Heating and Cooling type	240 SEC.
n.d \bar{c}	n, Differential time of cooling side (D)	OFF / 1 ~ 6000 초	Heating and Cooling type	60 SEC.
n.db	n, Hysteresis band	-100,0 ~ 50,0 %	Heating and Cooling type	3,0 %
n.rP	n, Zone position setting	EU (0) < 1,RP < 2,RP < EU (100,0 %)	ZONE=ON	EU (100,0 %)

5) Heater break alarm (HBA) group setting

In the HBA setting group, a dedicated Current transformer(CT) may be set to monitor the AC current in a heater and to provide warning in case of malfunction. The threshold current level of the HBA may be set, and it may also be used to monitor electrical consumption.
(AC Current transformer (CT) : CTL-6-S or an 800:1 all-purpose CT may be used.)

Display	Description	Setting range	Condition	Initial Value
4.HbA	Enter to heater break alarm Setting group	-	Option	-
HbA	Current setting of HBA	OFF / 1 ~ 50 A	HBA option	OFF
Hdb	Hysteresis setting of HBA	0 ~ 50 A		1
Hcn	Measuring value of HBA	0 ~ 50 A		-

HBA is generated through alarm output 1, and "alarm #1 type selection" must be set on code 21 in order for HBA to function.

HBA cannot be used when control output is in SCR mode (4~20mA).

6) Alarm (Alarm 1, 2) group setting

The T50 series has two separate alarm outputs, and in the setting group, alarms may be chosen among 21 types, and the dead band (hysteresis) for the alarm output may be set. Please find the alarm code with the desired function in the "Alarm output type and Selection code" on the next page and use it to set the alarm output type in the settings mode.

Display	Description	Setting range	Condition	Initial Value
5.ALn	Enter to alarm setting group	-	Always	-
A1TY	Alarm 1 output selection	OFF / 1 ~ 21	Always	1
A2TY	Alarm 2 output selection	OFF / 1 ~ 20	Alarm option	2
A1db	Hysteresis of alarm 1 output	EUS (0,0 ~ 100,0 %)	Always	EUS (0,5%)
A2db	Hysteresis of alarm 2 output		Alarm option	EUS (0,5%)
AL1	Alarm 1 output value setting	PV alarm, Deviation alarm EU (-100,0 ~ 100,0 %)	Always	EU (100,0%)
AL2	Alarm 2 output value setting		Alarm option	EU (0,0%)

The HBA will be generated through alarm output #1 (when A1TY = 21).

This means that HBA may be set only through alarm output #1.

(1) Alarm output type and Selection code

CODE NO.	ALARM TYPE	ALARM OUTPUT OPERATION
01	Absolute value upper-limit	<p>When temperature is falling: OFF → ON</p> <p>When temperature is rising: OFF → ON</p> <p>Temperature: Low → High</p> <p>Alarm setting value</p>
09	(Inverted output)	
11	with hold function	
19	with hold function (Inverted)	
02	Absolute value lower-limit	
10	(Inverted output)	
12	with hold function	
20	with hold function (Inverted)	
03	Upper-limit deviation	<p>(Negative temp. value setting) (Positive temp. value setting)</p> <p>When temperature is falling: OFF → ON</p> <p>When temperature is rising: OFF → ON</p> <p>Temperature: Low → High</p> <p>-Alarm SV Alarm setting value</p>
05	(Inverted output)	
13	with hold function	
15	with hold function (Inverted)	<p>(Negative temp. value setting) (Positive temp. value setting)</p> <p>When temperature is falling: ON → OFF</p> <p>When temperature is rising: ON → OFF</p> <p>Temperature: Low → High</p> <p>SV -Alarm Alarm SV</p>
04	Lower-limit deviation	
06	(Inverted output)	
14	with hold function	
16	with hold function (Inverted)	
07	Upper & Lower-limit deviation	<p>When temperature is falling: ON → OFF → ON</p> <p>When temperature is rising: ON → OFF → ON</p> <p>Temperature: Low → High</p> <p>Alarm SV Alarm SV</p>
17	Upper & Lower-limit deviation with hold	
08	Upper & Lower-limit deviation in range	
18	Upper & Lower-limit deviation in range with hold	
21	Heater break alarm (HBA1)	Refer to HBA ! (ALARM1 only)

When alarm type reverse-correspondence is selected for alarm type and code, please be aware that when the alarm lamp turns on, the contact output will be off.

Example of Alarm output 1 setting

- ALTY** Alarm type (Upper-limit deviation) = 03
- ALdb** Hysteresis (Dead band) = 2 °C
- AL1** Alarm setting value = 20 °C

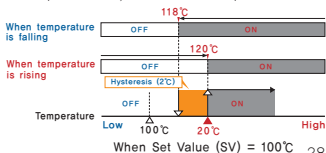

(2) Hold function

When a low alarm is set and during temperature is rising, an unnecessary low alarm may happen. The hold function may be used to eliminate such problems.

The hold function allows the low alarm to be ignored automatically until the temperature rises above the alarm threshold level for the first time when electricity is first turned on.

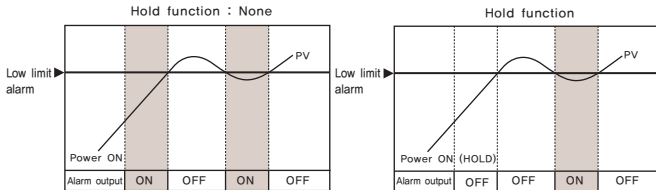

7) Retransmission group setting

In the retransmission output mode, process value (PV), set value (SV), manipulated variable (MV) or sensor power supply (SPS) may be chosen, and the output will be generated in direct current of 4~20mA. (SPS is DC15V/25mA)

Display	Description	Setting range	Condition	Initial Value
Err4	Enter to retransmission setting group	-	Option	-
rEt	Retransmission type or SPS selection	PV / SV / MV / SPS	Option	PV
rEt.H	Highest limit of retransmission	TC or RTD : Fr-H ~ Fr-L Voltage : SL-H ~ SL-L (But, RET.H > RET.L)	PV or SV selection	EU (100.0%)
rEt.L	Lowest limit of retransmission			EU (0.0%)

PV(Current Progress Value) /SV(Set Value) /MV(Manipulated Variable) /
SPS(Power supply for external sensor)

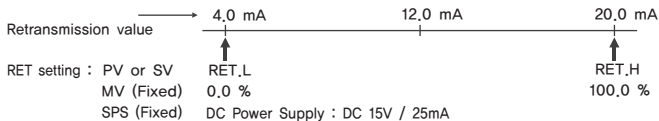

8) Communication group setting

The communication system of the T50 series is based on RS-485, and is a two-wire half-duplex type, capable of connecting to a maximum of 32 devices. In particular, it is a totally independent isolation structure, which very safe and reliable, and is compatible with most communication protocols used in the market (PC-Link, TL-Link, Modbus-ASCII, Modbus-RTU, Sync-Master/Slave).

Display	Description	Setting range	Condition	Initial Value
	Enter to communication setting group	-		-
	Protocol selection (PC/TL-Link, Modbus-ASCII/ RTU, Sync-Master/Slave)	HSTD / HSUM / H-TL MODA / MODB SYNM / SYNS	Optional	H-TL
	Baud rate selection (B.P.S)	600 / 1200 / 2400 / 4800 / 9600 [BPS]		9600 BPS
	Parity check selection	NONE / EVEN / ODD		NONE
	Stop bit selection	1-bt(bit) / 2-bt(bit)		1-bt
	Data Length selection	7-bt(bit) / 8-bt(bit)		8-bt
	Address selection	1 ~ 99 (Max, 32 devices)		1
	Response time selection	0 ~ 10 (Response time = Handling time + Response time) x 10ms		1

The T50 series has a totally isolated input-output structure. A maximum of 32 devices may be connected to it, but this number may vary according to the site and the line conditions.

(1) Communication protocols in detail

① HSTD / HSUM

PC-Link is used by some in Korea, developed by 2 corporations.

② H-TL (TL-Link)

This is Temcoline's own protocol. The multi-remote surveillance program, which is included in the optional communications package for the T50 series, uses this protocol. (For the reference, this program has advanced recording functions)

③ MODA (Modbus-ASCII)

This ASCII-based protocol is commonly used in the industry, and is easy to use.

④ MODB (Modbus-RTU)

This binary-based protocol is the most widely used standard protocol in the industry, and has a high speed.

⑤ Sync-Master/Slave

A system of Sync communication is configured with a master controller and a number of slave controllers (up to 200 units). The slave controllers are set to operate in the same way as the master controller, this time running information (SV1, SV2, SV3, SV No.) is transmitting to slave controllers from master controller.

(2) Modbus protocol and T50 series

The Modbus communication protocol function code in the T50 series is comprised of a function code that reads and writes D-REGISTER, and another that searches for Loop-Back. For more information, please refer to the separately distributed Temcoline protocol, or contact us by our website or our customer service center.

[Modbus protocol support code]

Code	Description	
03	D-REGISTER consecutive READ	The device is capable of reading up to 32 consecutive D-Register contents.
06	Single D-REGISTER WRITE	The D-Register contents can be edited one at a time.
08	DIAGNOSTICS (LOOP-BACK TEST)	This can be used for self-diagnosis and testing purposes.
16	D-REGISTER consecutive WRITE	The device is capable of writing up to 32 consecutive D-Register contents.

The Modbus support device uses as address #400001~400999 in the 16-bit holding register range, which includes 400001~465536.

When using a touchscreen for interface, the read/write addresses must be set at 400001 (D-Reg. 000) ~ 400700 (D-Reg. 699) for Pro-Face products,

For EasyView products, the device setting must be at 4x (16-bit), and the address at 001 (D-Reg. 000) ~ 700 (D-Reg. 699).

In Modbus communication, the address will be designated as the real communication frame address +1. This is because the user may choose addresses from #400001 onward. (Example: #400001 = D-Reg. 000)

(3) Modbus communication setting

① Modbus-ASCII

COM.P : MODA, BPS : 9600, PRTY : EVEN, STOP : 1-BT(bit), DTLN : 7-BT(bit)

② Modbus-RTU

COM.P : MODB, BPS : 9600, PRTY : EVEN, STOP : 1-BT(bit), DTLN : 8-BT(bit)

(4) Sync-Master/Slave Communication set

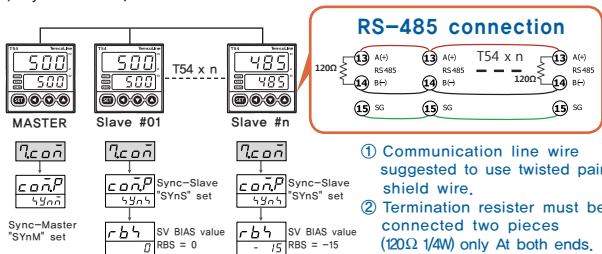

Master controller can be set only one and others should be set as Slave. In Sync communication, no need to set Address and communication option. When set in Slave (Syncs), it works RBS menu.

(5) Sync–Master/Slave applications such as the best case

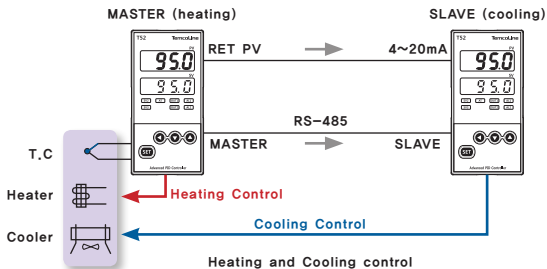

〈 Heating and cooling system synchronously 〉

- ① PID Controller models should be supported communication and retransmission function.
- ② Sync Communication to specify Master and Slave, Slave is set to the input No.30 (1~5V input).
- ③ Selection for output action, set reverse to Master and direct to Slave.
- ④ Master set to retransmission type to PV also, set to limit of high and low retransmission.
- ⑤ Set SV and start auto-tuning both at the same time.
- ⑥ After auto-tuning, set RBS value of slave (cooling) to +0.5~2.0 for dead band of slave.

(6) Precision calibration method of retransmission

In case, retransmission output(4~20mA) some errors may occur by resistor of convert and connected other device. If you need to have precised retransmission, you can calibrate easily as described below.

- ① For example, retransmission output limit value(RET,H) is 100.0, Lower value(RET,L) is 0.0 assuming to.
- ② Retransmission mode changes to SV from PV. Transfer current value of RET.H(100.0) as changed SV. Check value for recorder or receiver side temperature(ex, 99.6) and note.
Transfer current value of RET.L(0.0) to as changed SV check value for recorder or receiver side temperature(ex, 0.3) and note.
- ③ Note that the value of the retransmission output upper limit (RET.H) to change to 99.6, lower limit (RET.L) to change to the 0.3.
- ④ Retransmission mode (RET) change to the PV from SV, retransmission output mode calibration is completed.

(7) T50 D-REGISTER MAPPING
 READ ONLY READ/WRITE

ADDRESS	PROCESS	CTRL	PGM	SV/PID	HBA/ALM	RET/COM	OUT/IN
Modbus	0	100	200	300	400	500	600
400 001	0			SVNO	HBA1	RET	OUT
400 002	1	N,PV		SV1	H1DB	RET,H	O,ACT
400 003	2	N,SV	ZONE	SV2		RET,L	CT
400 004	3	N,SVNO	FUZY	SV3			CTC
400 005	4		ARW				HYS
400 006	5	M,OUT		AT,M			PO
400 007	6		DIS	AT			POC
400 008	7						OL-H
400 009	8	PID,N	UP,RT				OL-L
400 010	9	ALM,S	DN,RT				
400 011	10		RTMU	1,P	A1TY	COM,P	INP
400 012	11			1,I	A2TY	BPS	UNIT
400 013	12			1,D		PRTY	FR-H
400 014	13			1,MR	A1DB	STOP	FR-L
400 015	14	HCM1		1,Pc	A2DB	DTLN	DP-P
400 016	15			1,lc		ADDR	SL-H
400 017	16	ADE,S		1,Dc	AL-1	RSPN	SL-L
400 018	17	ERR,S		1,DB	AL-2		FILT
400 019	18	MOD,S		1,RP			BIAS
400 020	19						B,OUT
400 021	20			2,P			
400 022	21			2,I			
400 023	22			2,D			
400 024	23			2,MR			
400 025	24			2,Pc			
400 026	25			2,lc			
400 027	26			2,Dc			
400 028	27			2,DB			
400 029	28			2,RP			
400 030	29						
400 031	30			3,P			
400 032	31			3,I			
400 033	32			3,D			
400 034	33			3,MR			
400 035	34			3,Pc			
400 036	35			3,lc			
400 037	36			3,Dc			
400 038	37			3,DB			
..	..						
..	..						
400 099	98						

When using the communication options, please refer to the separately provided T50 series communication protocol manual. Only the basics are outlined here.

9) Output group setting

The T50 series is categorized into S (standard) and D (heating/cooling) types, and has both multiple inputs and outputs. The user may select among relay, SSR, or SCR (4~20mA, DC) for output.

Display	Description	Setting range	Condition	Initial Value
B.out	Enter to output setting group	-	-	-
out	Output type selection	0 (on/off) / 1 (SSR) / 2 (SCR) / 3 (Relay), (Refer to PB, 2)	Always	1 (SSR)
oAct	Output action selection	REV (Reverse action) / DIR (Direct action) (REV: Heating, DIR: cooling)	Always	REV
ct	Cycle time	1 ~ 1000 sec.	SSR / RELAY control	2 sec.
ctc	Cycle time of cooling output	1 ~ 1000 sec.	D-TYPE	20 sec.
HY4	Hysteresis (ON/OFF control)	EUS (0,0~100,0 %)	ON/OFF control	EUS (0,5%)
HY4t	Hysteresis action selection when ON/OFF control	HALF / NORMAL	ON/OFF control	NORM
Po	Output 1 volume when input disconnected (OUT1)	-5,0 ~ 105,0 %	Always	0,0 %
Poc	Output 2 volume when input disconnected (OUT2)	-0,0 ~ 105,0 %	Heating & Cooling Model	0,0 %
oL-H	High limit of output	OL-L ~ 105,0 %	PID control	100,0 %
oL-L	Low limit of output	-0,5 % ~ OL-H	PID control	0,0 %

In PID control, output interval (Ct) will be 20 seconds if relay (code 3) is selected, when SSR (code 1) is selected, output interval will be automatically set at 2 seconds. You may change this manually.

(1) Setting output amount for the event that input has been cut off (Po)

If there is a problem with the input sensors or if for any reason the temperature controller does not function properly, this safety function shuts off internally controlled output or maintains steady output at a desired level.

(2) Output limitation in high/low (OL-H, OL-L)

Since the T50 series uses the S-PID algorithm, this function is not necessary in most cases. This function may be used when special circumstances require limiting the output. Using the default value (0~100,0%) is recommended.

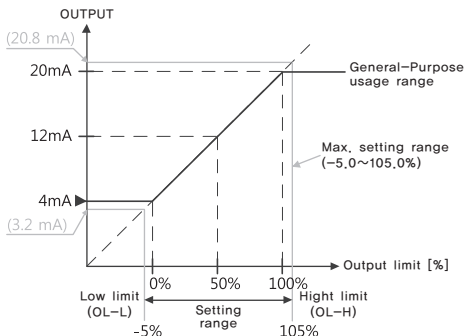

(3) Selection function for Hysteresis(ON/OFF control mode OUT=0)

(1) HYS.T = "NORM" selection

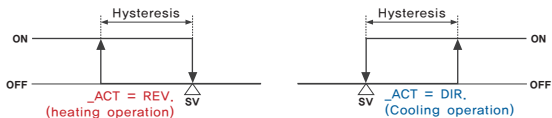

(2) HYS.T = "HALF" selection

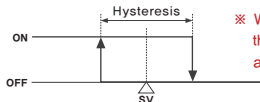

※ While Hysteresis operation in "HALF" mode, the operation of Heating and cooling is same, and "NORM" is factory default.

10) Input group setting

The T50 series supports a wide range of specifications, including 12 types of thermocouples (TC), 2 types of platinum resistance thermometers (RTD), and 3 types of current and voltage inputs,

Display	Description	Setting range	Condition	Initial Value
9.Ln	Enter to input setting group	-	-	-
LnP	Input type selection	1 ~ 33 (refer to P7, 2-1.)	Always	1
unLt	Input temperature unit selection	°C / °F	TC or RTD input	°C
Fr-H	High limit	Within input range (refer to next page) but, Fr-H > Fr-L	Always	1370
Fr-L	Low limit		Always	-200
dP-P	Decimal point positioning (On voltage input)	0 / 1 / 2 / 3 (On voltage input)	On voltage input (mV, V)	1
SL-H	Scale high (On voltage input)	-1999 ~ 9999 But , SL-H > SL-L Decimal point positioning by DP-P	On voltage input (mV, V)	100.0
SL-L	Scale low (On voltage input)			0.0
FLLt	Input digital filter	OFF / 1~120 sec.	Always	OFF
bLA4	Input value correction	EUS (-100.0~100.0 %)	Always	EUS (0.0 %)
GA.Ln	correcting upper limit of input	EUS (-100.0~100.0 %)	On voltage input (mV, V)	EUS (0.0 %)
bout	Burn-out selection	OFF / UP / DOWN	Always	UP

When the input type is changed, all parameters are reverted to their factory default. This means that before using the T50, the input type needs to be set first, after which other parameters can be configured. If the input settings are changed while in use, auto-tuning and other parameters need to be reconfigured.

(1) Input type selection

This is the first thing that needs to be checked and set before using the T50, as the settings here will cause other parameters to be reset to their typically optimal values for that specific type.

(2) Input unit selection (°C / °F)

This selects the unit of temperature measurement to be displayed when using temperature sensors. The Celsius degree is set as the default, but it may be changed to the Fahrenheit degree. On products sold in Korea, the units are fixed to the Celsius degree in compliance with the regulations.

(3) Setting decimal point position (DP-P), and free scale high and low limits (SL-H, SL-L)

This applies only when using voltage inputs (DC V, mV) or currents between 4 to 20mA (1~5V). The user may set ranges, units and decimal point position as desired. This can be used not only for temperatures but also for a number of other measurements, including humidity, pressure, and weight.

(4) Digital input filter (FILT)

This function is useful when suboptimal environments cause noises or severe fluctuations, enabling a digital software filter. The filter's sensitivity may be set from off to 1~120 seconds. Please be careful when using this function, as it may affect the control-related algorithms.

(5) Input value bias (BIAS)

This function allows the input values to be compensated. This function is useful, for example, when sensors can not be placed at desired locations, or when several different thermometers are used in conjunction. The values may be compensated to extent desired by the user.

(6) Correcting upper limit of input value(GAIN)

Use only in voltage input(current 4~20mA) mode. This can accurately correct the deviation occurred by output error of sensor module and an error of conversion resistance (250 Ω).

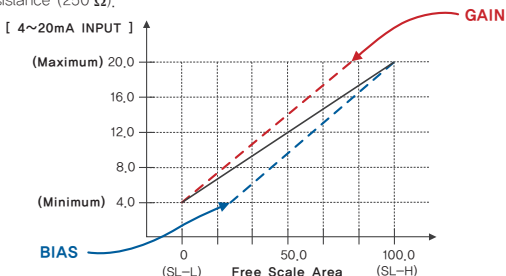

Ex.) When using DC 4~20mA input, the lower value, 4mA can be corrected at "BIAS" mode and higher value, 20mA corrected at "GAIN" mode. To have more accurate correction, firstly set the lower value at "BIAS" mode and then set the higher value at "GAIN" mode. T50 series offers the powerful correction function with 4~20mA conversion resistance (250 Ω) at competitive prices.

11) Error indication during operation

- B.OUT : INPUT SENSOR error or burn out etc.
- +OVR : Out of maximum input range (refer to input group setting) or overheating
- OVR : Out of minimum input range (refer to input group setting) or overcooling
- SYS.E : SYSTEM setting error or Memory damage (request for repair)
- RJC.E : RJC Sensor damage or PCB burn (request for repair)
- EPP.E : EEPROM damage (request for repair)
- COM.E : Communication ERROR (request for repair)
- AT.E : Auto Tuning Error, Checking heater break or controller

TemcoLine™
www.temcoline.com



ARGO CONTROL

 **:051-37133855-6**

 **:09014284236**

WWW.ARCOKALA.COM

TEMCOLINE Co., Ltd.

Misung Bldg, 217-1, Gurojungang-ro, Seoul, 152-865 Korea

Tel. +82-2-3667-5521 Fax. +82-2-2632-5549

E-Mail: sales@temcoline.com